

LOG OF PROJECT

US-10: Hersey River to east of US-10BR
Osceola County
CS 67021/67022
Page 1 of 6

PROJECT LOCATION

This project begins on US-10 at the east approach of B02 of 67011 (US-10 over the Hersey River). The point of beginning is station 254+85 (CS 67021, C.S.M.P. 2.524). The project continues easterly along US-10 to a point 280' east of US-10 BR. The point of ending is Station 262+67 (CS 67022, C.S.M.P. 0.053). This project length is 0.148 miles.

There is one control section change:

CS 67021, M.P. 2.619 (Station 259+87) BK = CS 67022, M.P. 0.000 (Station 259+87) AH

PROJECT DESCRIPTION

This project provides for 0.148 miles of Cold Milling and HMA Resurfacing to the existing pavement and paved shoulders and pavement markings, on US-10 through Richmond Township and the City of Reed City in Osceola County.

PROGRESS CLAUSE

Start work within 10 days after receiving the notice of award or contract or as approved by MDOT project staff. In no case shall work commence prior to receipt of formal notice of award.

The entire project shall be completed on or before August 21, 2026

ITEMS OF WORK

Cold Milling, Resurface

In accordance with the typical cross sections, special details, Standard Plans, and the 2020 Standard Specifications for Construction, cold mill and resurface existing lanes and HMA shoulders per typical from Sta 254+85 (POB) to Sta. 262+67 (POE).

Cold Milling HMA Surface HMA, 4EMH, High Stress	5,192 572	Syd Ton
--	----------------------	--------------------

LOG OF PROJECT

MAINTAINING TRAFFIC

Maintain traffic in accordance with the SPECIAL PROVISION FOR MAINTAINING TRAFFIC and as directed by the Engineer.

Channelizing Device, 42 inch, Fluorescent, Furn	60	Ea
Channelizing Device, 42 inch, Fluorescent, Oper	60	Ea
Traf Regulator Control	1	LSUM
Sign, Type B, Temp, Prismatic, Furn	588	Sft
Sign, Type B, Temp, Prismatic, Oper	588	Sft
Pavt Mrkg, Wet Reflective, Type R, Tape, 6 inch, Yellow, Temp	165	Ft
Pavt Mrkg, Wet Reflective, Type R, Tape, 6 inch, White, Temp	625	Ft
Barricade, Type III, High Intensity, Double Sided, Lighted, Furn	7	Ea
Barricade, Type III, High Intensity, Double Sided, Lighted, Oper	7	Ea
Connected Arrow Board, Type C, Furn	3	Ea
Connected Arrow Board, Type C, Oper	3	Ea
Sign Cover	25	Ea

The following quantities are provided for information only. Actual quantities will be paid for per the 2020 Standard Specifications for Construction.

Code	Type	Legend	Size	Area (Sft)	Number	Qty (Sft)
W3-4	B	BE PREPARED TO STOP	48"X48"	16	3	48
W20-1	B	ROAD WORK AHEAD	48"X48"	16	4	64
W20-2	B	DETOUR AHEAD	48"X48"	16	4	64
W20-3	B	ROAD CLOSED AHEAD	48"X48"	16	4	64
W20-4	B	ONE LANE ROAD AHEAD	48"X48"	16	3	48
W20-7a	B	SYMBOLIC FLAGGER	48"X48"	16	3	48
G20-2	B	END ROAD WORK	48"X24"	8	3	24
M1-4	B	US-10 SHIELD	24"X24"	4	18	72
M4-3	B	BUSINESS	18"X9"	1.125	18	20.25
M4-8	B	DETOUR	18"X9"	1.125	18	20.25
M4-8a	B	END DETOUR	24"X18"	3	2	6
M4-10L	B	LARGE DETOUR ARROW	48"X18"	5	1	6
M4-10R	B	LARGE DETOUR ARROW	48"X18"	6	1	6
M5-1L	B	ADVANCE LEFT TURN	21"X15"	2.1875	2	4.375
M5-1R	B	ADVANCE RIGHT TURN	21"X15"	2.1875	2	4.375
M6-1L	B	LEFT TURN	18"X12"	1.5	2	3
M6-1R	B	RIGHT TURN	18"X12"	1.5	2	3
M6-3	B	STRAIGHT	18"X12"	1.5	1	1.5
R5-18c	B	WORK ZONE BEGINS	48"X48"	16	3	48
R11-2	B	ROAD CLOSED	48"X30"	10	2	20
R11-4	B	ROAD CLOSED TO THRU TRAFFIC	60"X30"	12.5	1	12.5

LOG OF PROJECT

Page 3 of 6

ENTIRE PROJECT QUANTITIES

The following quantities are estimated for use where needed throughout the project as directed by the Engineer.

Mobilization, Max \$6,500	1	LSUM
Pavt Mrkg, Waterborne, 6 inch, White	1,812	Ft
Pavt Mrkg, Waterborne, 6 inch, Yellow	2,084	Ft
Pavt Mrkg, Ovly Cold Plastic, Lt Turn Arrow Sym	3	Ea
Pavt Mrkg, Ovly Cold Plastic, Rt Turn Arrow Sym	3	Ea
Pavt Mrkg, Ovly Cold Plastic, 24 inch, Stop Bar	95	Ft
Pavt Mrkg, Ovly Cold Plastic, 12 inch, Cross Hatching, Yellow	43	Ft

GENERAL NOTES

UTILITIES

MISS DIG/UNDERGROUND UTILITY NOTIFICATION

Contact MISS DIG System, Inc. for the protection of underground utilities and in conformance with MCL 460.721 et seq, by phone at 811 or 800-482-7171 or via the web at <http://www.missdig811.org/>, a minimum of 3 working days prior to excavating, excluding weekends and holidays.

MDOT's roadway lighting system, Intelligent Transportation Systems (ITS) and other miscellaneous electrical systems are not part of MISS DIG. Contractors shall contact the following at least 5 business days in advance for staking requests. Note that these are not emergency contacts for damage to utilities.

Grand Region

All Grand Region staking requests shall be submitted using MDOT form 5300: <https://mdotjboss.state.mi.us/webforms/GetDocument.htm?fileName=5300.pdf>

Telephone inquiries can be made by calling the Grand Region Office at 616-451-3091

OLD PLANS

OLD ROAD PLANS

The following old road plans were referred to in the design of this project.

- C.S. 67021/67022 – J.N. 4503A – 1998 HMA Overlay
- C.S. 67021/67022 – J.N. 204027A – 2020 Mill/Fill
- C.S. 67021 – J.N. 211438A – 2024 Bridge B02 of 67021

In addition, other old road plans that predate this project may be available. These plans may be reviewed in the Transportation Service Center (TSC) during normal working hours.

PROJECT SPECIFIC NOTES

SURVEY

STATIONING

Stationing on this project was taken from Right of Way plans (File 67-R-2), and distance meter readings which are not necessarily accurate. The stationing is relative to this project only and does not correspond to other stationing in the area. The following road Stationing and Control Section Mile Point (CSMP) locations are given for approximate correlation and information only.

<u>US-10</u>	<u>CSMP</u>	<u>STA</u>
POB	2.524	254+85
US-10 BR	0.000	259+87
POE	0.053	262+67

SUBMITTAL LIST

MDOT Form 501 Materials Source List

HMA Quality Control Plan

Contractor Safety Program

Progress Schedule

Safety Program

Damage Claim Program

Form 1911 Job Mix Formula HMA Field Communication

LOG OF PROJECT

Page 5 of 6

NOTES APPLYING TO STANDARD PLANS

Where the following items are called for on plans, they are to be constructed according to the standard plan given below opposite each item unless otherwise indicated.

Title	Plan No.
PAVEMENT MARKINGS	
TEMPORARY LONGITUDINAL LINE TYPES AND PLACEMENT	PAVE-904-B
LONGITUDINAL LINE TYPES AND PLACEMENT	PAVE-905-F
PAVEMENT MARKINGS FOR NON-SIGNALIZED INTERSECTIONS	PAVE-930-E

* **Denotes Special Detail**

LOG OF PROJECT

Page 6 of 6

Itemized Bid Sheet

Contractor will provide a lump sum cost for performing the work detailed in the log of project.

Item Description	Quantity	Units	Unit Price	Total Price
US-10 at US-10 BR Paving	1	LSUM		

Company Name	
Company Address	
City, State, Zip Code	
Telephone Number	
Email	
Name (Printed)	
Signature	
Date	

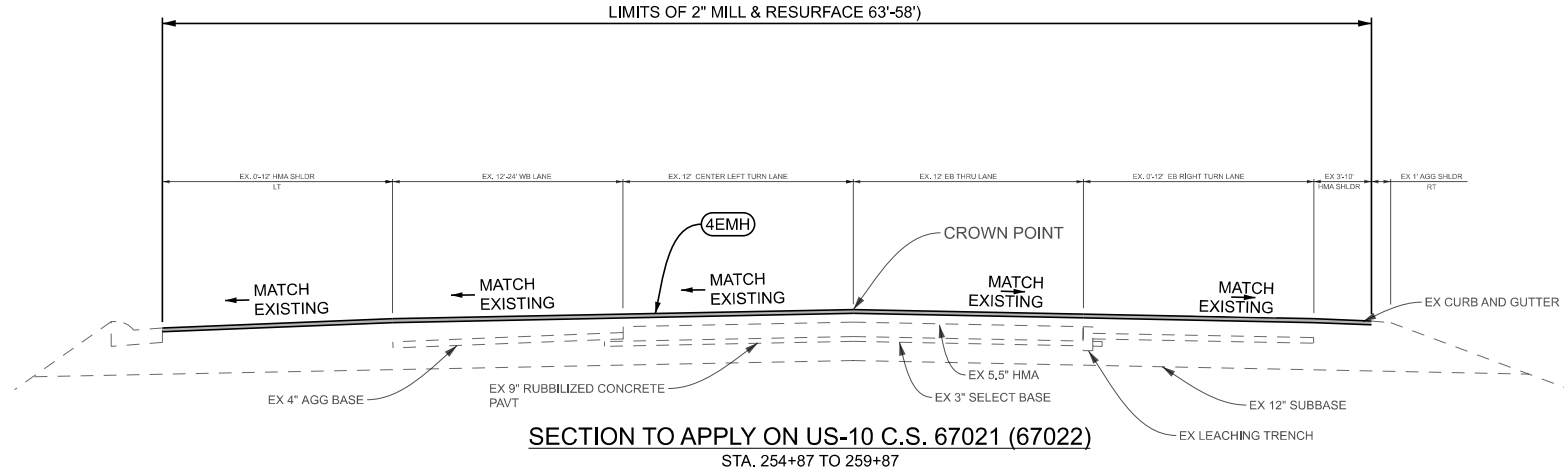
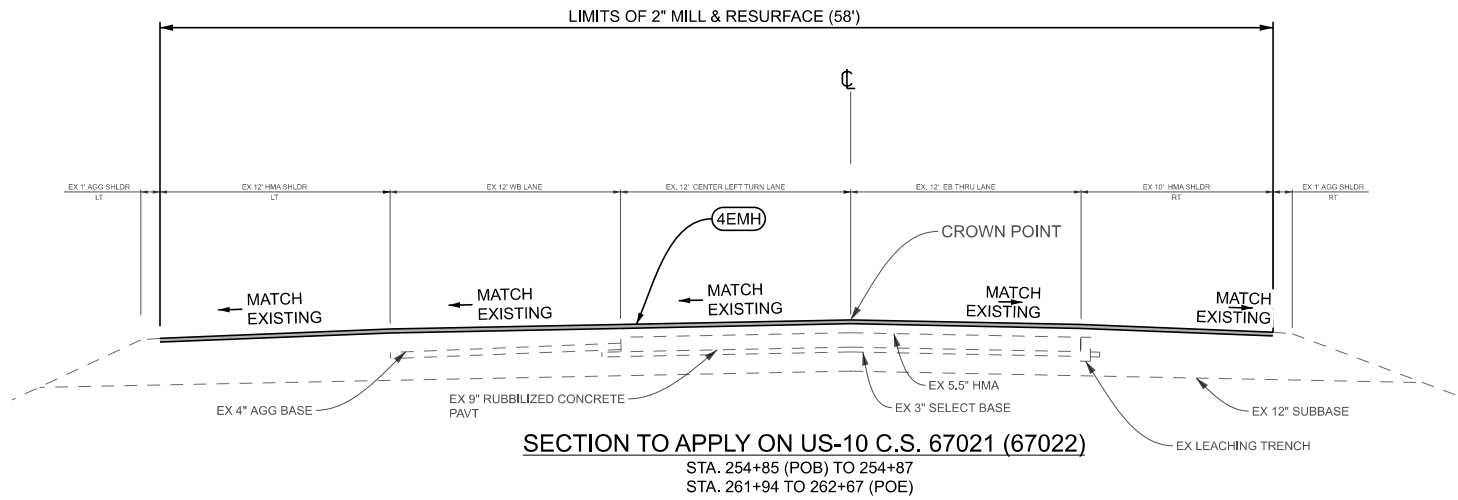

HMA APPLICATION ESTIMATE

IDENT NO.	ITEM	RATE LBS PER SYD	PERFORMANCE GRADE	REMARKS
4EMH	HMA, 4EMH, HIGH STRESS	220	70-28	AWI=280
	* BOND COAT	0.05-0.15 GAL		

* FOR INFORMATION ONLY

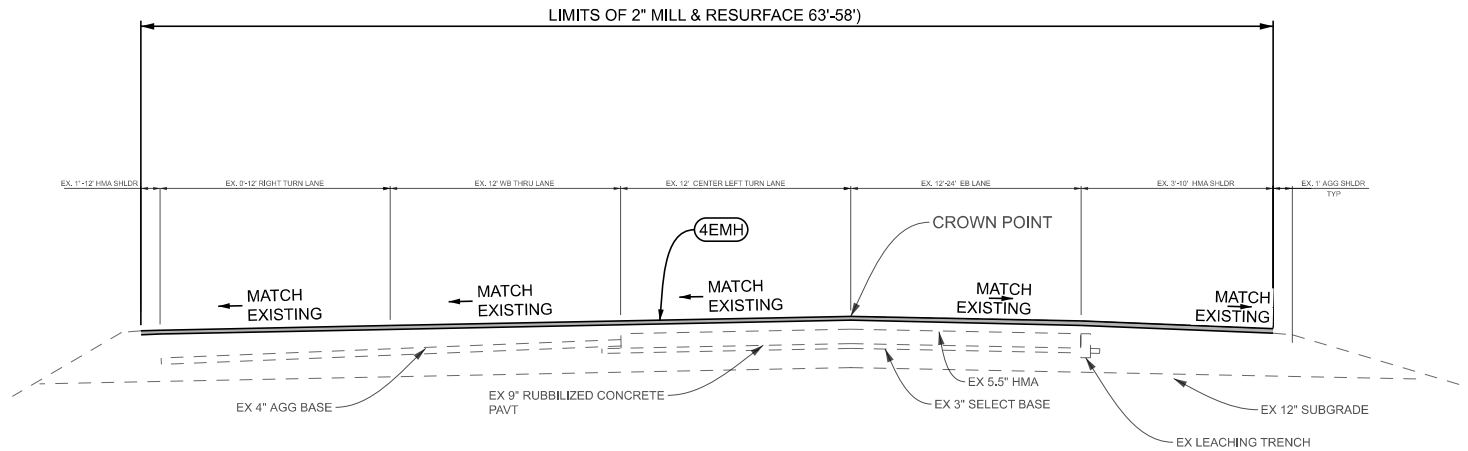

SECTION TO APPLY ON US-10 C.S. 67021 (67022)
 STA. 259+87 TO 261+94

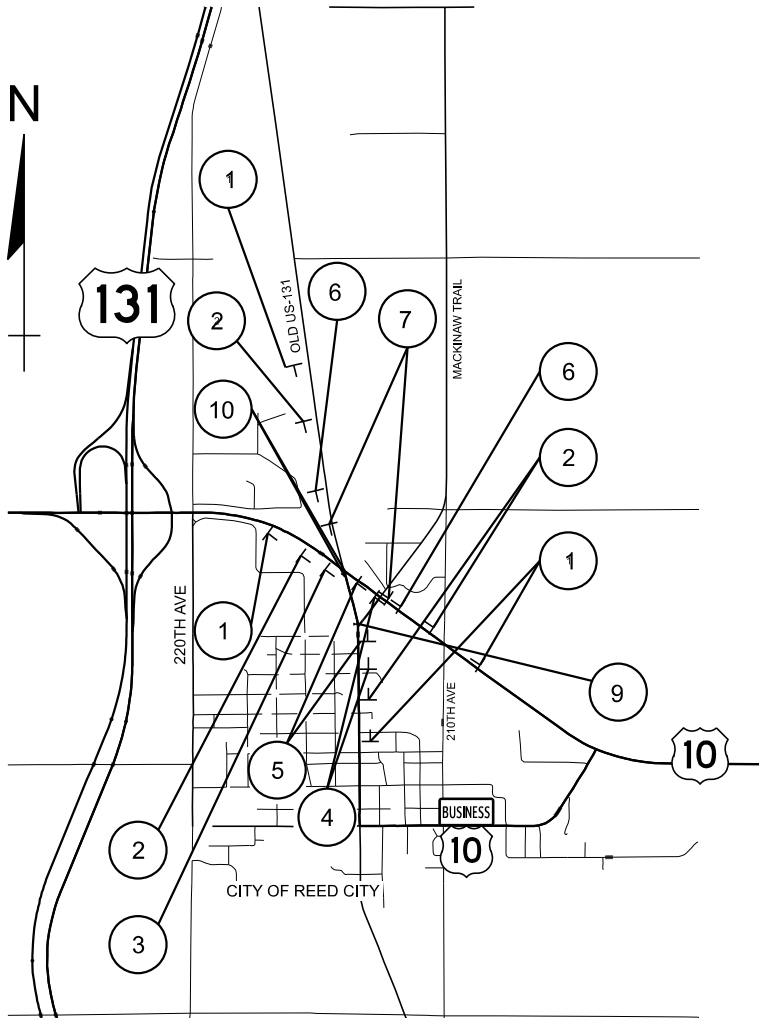

W20-3
48"

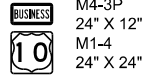

W20-2
48"

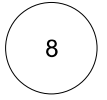
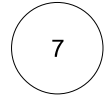
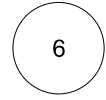
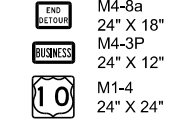
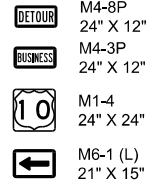
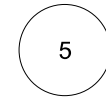
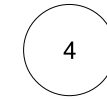
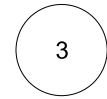
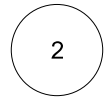
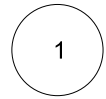
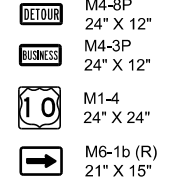
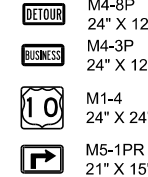
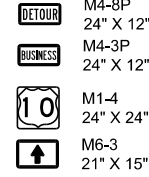
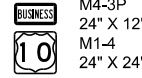

ERECT R11-2 BEHIND BARRICADE ON SEPARATE SIGN SUPPORTS
SUPPLY ENOUGH TYPE III BARRICADES TO COMPLETELY CLOSE
ROAD BETWEEN SHOULDER EDGES OR CURB FACES.

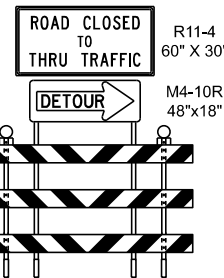

R11-4
60" X 30"

M4-10R
48"x18"

ERECT R11-4 BEHIND BARRICADE ON SEPARATE SIGN SUPPORTS.
PLACE TYPE III BARRICADE, R11-4 AND M4-10R ON THE SHOULDER.

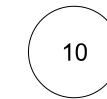
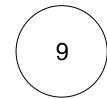

FILE: 224164_Typ.dgn

NO SCALE

DATE: 4/30/26
DESIGN UNIT:
TSC: CADILLAC

CS: 67021, 67022
JN:

DETOUR PLAN
US-10 BR

DRAWING SHEET
SECT 1

MICHIGAN
DEPARTMENT OF TRANSPORTATION

SPECIAL PROVISION
FOR
MAINTAINING TRAFFIC

CAD:DRW

1 of 7

a. Description. This special provision consists of requirements and restrictions to maintain traffic for on US-10 in the city of Reed City, Richmond Township, Osceola County.

b. General. Maintain traffic throughout the project in accordance with the standard specifications, typicals, and supplemental specifications in the contract and as described on the plans for this project.

c. Construction Influence Area (CIA). The CIA includes the right-of-way of the following roadways, within the approximate limits described below:

1. On US-10 from approximately 1 mile east of US-10BR (Old US-131) to 1 mile west of US-10BR (Old US-131).

2. In addition, the CIA includes the right-of-way of any designated detour route or alternate route, intersecting roads and ramps adjacent to the work zone for a distance of approximately 1/4 mile in advance of the work zone or as far as the construction or detour signing extends. The roads include but are not limited to US-10 Business Route, Mackinaw Trail and Old US-131..

d. Traffic Restrictions. Maintain traffic in accordance with the Maintaining Traffic Typicals contained herein, except as noted below. Changes or adjustments to the Maintaining Traffic Typicals may be necessary to fit field conditions, subject to approval of the Engineer or as determined by the Engineer.

1. Utilize the following Maintaining Traffic Typicals:

- A. 100-GEN-KEY
- B. 101-GEN-SPACING-CHARTS
- C. 102-GEN-NOTES
- D. 103-GEN-SIGN
- E. 104-GEN-AB
- F. 106-GEN-SPEED-NFW
- G. 107-GEN-SPEED

H. 110-TR-NFW-2L

I. 112-TR-CLT

J. WZD-125-E

2. Do not deliver material, or close lanes during the holiday periods as defined in Table 1.

Table 1: 2026 Holiday Periods

Holiday	Start Date and Time	End Date and Time
Memorial Day	Noon, Thursday, May 21st	6:00 a.m. Wednesday, May 27th
Independence Day	Noon, Thursday, July 2nd	6:00 a.m. Tuesday, July 7th
Labor Day	Noon, Thursday, September 3 rd	6:00 a.m. Tuesday, September 8th

3. Do not deliver material, or close lanes during the Special Events as defined in Table 2

Table 2: 2026 Special Events

Local Event	Start Dates and Time	End Date and Time
Great American Crossroads Celebration	12:00 p.m. Thursday, August 13th	6:00 a.m. Monday, August 17 th

4. Perform work and lane closures within the allowable time frames as shown in Table 3 and 4, unless otherwise approved by the Engineer. Traffic switch operations on freeways may take place within the allowable times listed below in the traffic restriction tables and/or as otherwise approved by the Engineer. Additional lane, ramp, and/or roadway closures and shifts may be implemented during maintaining traffic stage and traffic switch operations with prior Engineer approval.

5. Traffic switch operations are exempt from lane rental assessments or liquidated damage assessments for 8 hours for each traffic switch. Perform traffic switch operations within the allowable "traffic restriction tables" as shown below.

- A. A traffic switch is defined as a change in the existing (original or staged) traffic configuration which requires multiple (more than one) lane lines and/or edge lines to be relocated in a new location and the old lines to be removed either between construction stages, or maintenance of traffic stages.

Table 3: US-10 Traffic Restrictions

Closure Type	Start Time	End Time	M	Tu	W	Th	F	Sa	Su
Shoulder Closures	00:00	24:00	∞	∞	∞	∞	∞	∞	∞
Single Lane Closures	☀	▼	∞	∞	∞	∞	0	0	0
☀ = half hour before sunrise as defined by the National Oceanic and Atmospheric Administration (NOAA) ▼ = half hour after sunset as defined by NOAA ∞ = Closure is allowed, and the frequency is not limited during the project timeframe # = The number of times closures can take place during the project timeframe.									

Table 4: US-10 Business Route Traffic Restrictions

Closure Type	Start Time	End Time	M	Tu	W	Th	F	Sa	Su
Shoulder Closures	00:00	24:00	∞	∞	∞	∞	∞	∞	∞
Single Lane Closures	☀	▼	∞	∞	∞	∞	0	0	0
Total Closure	00:00	08:00	0	0	0	0	0	0	0
	08:00	17:00	∞	∞	∞	∞	0	0	0
	15:00	24:00	0	0	0	0	0	0	0
☀ = half hour before sunrise as defined by the National Oceanic and Atmospheric Administration (NOAA) ▼ = half hour after sunset as defined by NOAA ∞ = Closure is allowed, and the frequency is not limited during the project timeframe # = The number of times closures can take place during the project timeframe.									

6. Maintain a minimum of one lane(s) of traffic in each direction at all times on US-10. (And all intersecting roads and ramps, except where detoured.)

7. No more than 1 closure is allowed in each direction of travel at the same time.

A. The maximum closure length is 1 mile unless otherwise approved by the Engineer.

8. Close any dedicated lanes (exit, ramp, turn, etc.) prior to the location under construction.

9. When a lane is closed, place channelizing devices at cross streets and major drives to form a radius that clearly defines the approaches to the through and turning traffic.

10. Unless otherwise directed by the Engineer, close entrance and exit ramps when working in the vicinity of the ramp(s).

11. Restrict access to US-10 from side roads for short durations at specific locations as the Engineer directs or approves. Where an intersection is closed or partially closed, allow the adjacent intersections one block to the east and west to remain open to traffic, unless otherwise approved by the Engineer.

12. Maintain access to all driveways as directed by the Engineer unless prior agreements are made with the respective property owners. The cost of constructing driveways part width will not be paid for separately but will be considered included in the cost of other driveway pay items.

e. Traffic General.

1. For any lane open to traffic, provide a minimum lane width of 11 feet with 2 feet of shy distance on both sides unless identified otherwise on plans.

2. Do not close lanes or utilize traffic regulation sequences where work can be accomplished with a shoulder closure. Do not occupy any part of the active traffic lane with personnel or equipment when utilizing a shoulder closure. Place lane closures and traffic regulation operations only in areas as show on the plans unless otherwise directed by the Engineer.

3. Prior to shifting traffic onto shoulders or opening any lanes/shoulders and/or ramps, remove, by sweeping all accumulated debris that has collected within the shoulder and/or within the closed lane/shoulder.

4. A speed reduction will not be used.

5. Protect the work area at the end of each day. Close all open access points on the project to traffic with Type III barricades or other devices approved by the Engineer.

6. The Engineer will be responsible for notifying emergency services, transit agencies, law enforcement and schools prior to any lane closures, detours or major traffic shifts. In addition, the Contractor will be responsible for working with and complying with any coordination that is necessary with the Department and emergency services, transit agencies, law enforcement and schools.

7. Obtain all necessary permits from local governments within areas of local jurisdiction, including noise/dust ordinance waivers when required, prior to placing construction signing on local roads.

A. Prior to placing construction signing on local roads, obtain an approved permit from the Osceola Road Commission and any local agencies.

8. Remove all temporary traffic control devices from MDOT right-of-way during any shut down periods unless needed for directly maintaining or channelizing traffic. No additional payment will be made for removal and/or redeployment of these devices except for in the case of an approved extension of time.

9. Cover or remove construction signing that refers to work zone speed when work at a location is planned to be inactive for a period greater than 1 day, unless otherwise specified on the plans or as directed by the Engineer.

10. Once work is initiated that includes any lane restrictions, that work must be continued daily until completed. A lack of work activity for more than 1 day will require the removal of lane closures at no expense to the Department.

f. Traffic Regulator Control.

1. Maintain two-way traffic at all times on US-10 using traffic regulator control. A traffic regulator sequence is allowed to cover a maximum closure length of 1 mile. Place the arrow panel, signs and channelizing taper for the traffic regulator operation at locations approved by the Engineer for adequate visibility by oncoming traffic.

2. Do not utilize more than 1 traffic regulator operation(s) at one time on US-10

3. Crossroads except where detoured should remain open to traffic at all times. Use intermediate traffic regulators at each intersection approach and commercial driveways within the closure limits, as directed by the Engineer. Use traffic regulator control as directed by the Engineer for cross street traffic while paving through intersections.

g. Detours.

1. Do not detour traffic until all proposed contract work on the detour route is completed, inspected, and approved by the Engineer.

2. Signs should be on both sides of the roadway when the work is taking place on the freeway or a boulevard section.

3. Cover all detour signs installed prior to closing a road or ramp. Do not uncover detour signing until just before the closure is in effect. Immediately remove or cover all detour signing upon opening the road or ramp to traffic.

h. Pedestrian or Non-Motorized Facilities.

1. Maintain all facilities in accordance with *The Americans with Disability Act (ADA)* requirements and the *Public Rights-of Way Accessibility Guidelines (PROWAG)*. Provide facilities equivalent to or better than the route a person would have encountered prior to construction activities.

2. Always keep sidewalk areas clear of any equipment or materials when the sidewalks are open to pedestrian traffic. When open to pedestrian traffic, maintain a 4 foot clear path on all sidewalks.

i. Hot Mix Asphalt (HMA) Work.

1. Resurface all HMA milled areas the same day as the HMA cold milling operation.

2. No traffic is allowed on the HMA milled surface, unless directed by the Engineer.

j. Traffic Control Devices. Ensure all traffic control devices are in accordance with the *MMUTCD* and must meet the "acceptable" criteria as defined in the *ATSSA* publication entitled "*Quality Guidelines for Temporary Traffic Control Devices and Features*" at the time of initial deployment and after each major stage change.

1. During non-working periods, place applicable advance signs and channelizing devices at specific locations, as directed by the Engineer, at no additional cost to the Department.

2. Notify the Engineer 24 hours in advance of when traffic control devices are being delivered to the project site, to allow for initial inspection of devices to take place.

3. Remove from the project site all traffic control devices (including detour signing) no longer needed for a particular operation and equipment for construction within 3 calendar days of reopening the shoulder/lane/roadway.

4. Channelizing Devices.

A. Ensure all devices have sufficient ballast to prevent moving or tipping. If moving or tipping occurs, place additional ballast, as directed by the Engineer, at no additional cost to the Department. No more than two ballasts are allowed on each channelizing device.

B. Do not use caution tape on channelizing devices for traffic control and/or pedestrian traffic control on this project.

5. Temporary Signs.

A. Additional W20-1 (ROAD WORK AHEAD) signs are included in the quantities to be placed on all intersecting or adjacent roads where construction activities may be encountered.

C. Fabricate, install, and remove temporary sign overlays on existing signs with the pay item for Sign, Type B, Temp, Prismatic, Furn. Attach the overlay in accordance with subsection 812.03.D.2 of the Standard Specifications for Construction.

k. Temporary Pavement Markings.

1. Remove conflicting pavement markings, pavement markings in taper/transition areas and other markings as directed by the Engineer, for operations occupying a location longer than 3 days. Durable markings in these areas should be covered rather than be removed.

2. Quantities for temporary tape to be placed during paving operations are based on the MDOT PAVE 900 Series standard plans.

3. When Type R or NR tape is used, ensure that all temporary pavement markings adhere to the pavement surface until permanent markings are installed.

4. Complete temporary pavement markings in each stage prior to shifting traffic as directed by the Engineer.

5. Replace all existing pavement markings that are removed for traffic control or obliterated during construction.

6. Delineate the edge line with 42" channelizing devices on 100' centers.

I. Measurement and Payment. Payment will be in accordance with the standard specifications unless otherwise specified. No additional payment will be made for the following activities:

1. Transporting traffic control items from site to site.
2. Providing sufficient vehicles and staff to make changes as-needed on site during work.
3. Providing sufficient vehicles and staff to remove closures from the roadway.

TYPICAL NUMBER KEY

CODES

AB = ARROW BOARD
 AW = ADVANCE WARNING
 C = CLOSURE
 CLT = CENTER LEFT TURN LANE
 CROSS = CROSSOVER
 CruSha = CRUSH AND SHAPE
 EM = EARLY MERGE
 EnR = ENTRANCE RAMP
 ExR = EXIT RAMP
 FW = FREEWAY
 GEN = GENERAL INFORMATION
 GORE = FREEWAY GORE AREA
 IN = INSIDE
 INT = INTERSECTION
 L = LANE
 (L) = LEFT
 LC = LANE CLOSURE
 LD = LONG DURATION

LO = LANE OPEN
 O = OUTSIDE (LANE CLOSURE)
 OUT = OUTSIDE OF SHOULDER
 MID = MIDDLE OF INTERSECTION OR ROAD
 NFW = NON-FREEWAY
 PARK = PARKING LANE
 PCMS = PORTABLE CHANGEABLE MESSAGE SIGN
 (R) = RIGHT
 ROLL = ROLLING ROADBLOCK
 RUM = RUMBLE STRIP
 SD = SHORT DURATION
 SHL = SHOULDER CLOSURE
 SIGN = SIGN
 SP = SPECIAL
 SPEED = SPEED
 STA = STOPPED TRAFFIC ADVISORY
 TR = TRAFFIC REGULATOR
 TS = TEMPORARY SIGNAL
 ZIP = ZIPPER MERGE

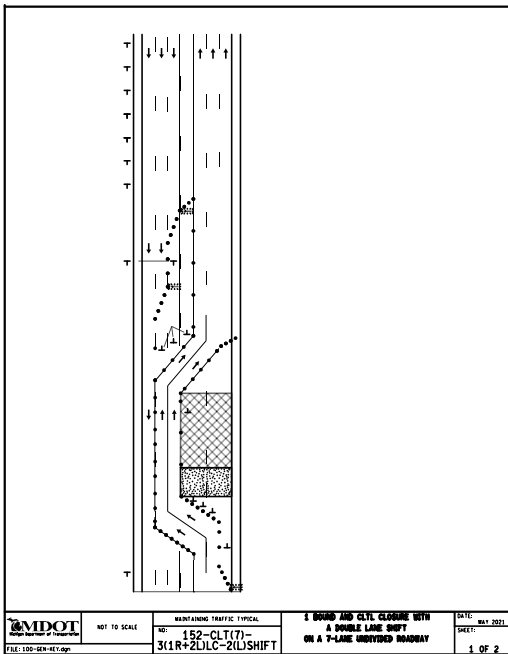

- 100 - GENERAL NOTES
- 110 - TRAFFIC REGULATORS
- 120 - NON-FREEWAY
- 130 - CENTER LEFT TURN (CLT) LANES
- 140 - PARKING LANES
- 150 - CLT 7 LANE SECTIONS
- 160 - SIGNAL WORK
- 200 - FREEWAY CLOSURES
- 210 - FREEWAY LANE SHIFTS
- 220 - FREEWAY ENTRANCE RAMPS
- 230 - FREEWAY EXIT RAMPS
- 300 - ADVANCE WARNINGS
- 310 - CROSSOVER CLOSURE
- 320 - CRUSH AND SHAPE
- 340 - MERGE SYSTEMS
- 350 - GORE LOCATIONS
- 360 - ROLLING ROADBLOCK
- 4000 - MAINTENANCE
- 5000 - SURVEY

EXAMPLE TYPICAL

CODE: 152-CTL(7)-3(1R+2L)LC-2(L)SHIFT

152 - TYPICAL NUMBER

CTL(7) = CENTER LEFT TURN LANE, 7 LANES TOTAL.

3(1R+2L)LC = 3 LANES CLOSED, (1 RIGHT LANE AND 2 LEFT LANES).

2(L)SHIFT = 2 LANES SHIFTED TO THE LEFT.

NOT TO SCALE

	NOT TO SCALE	MAINTAINING TRAFFIC TYPICAL	TYPICAL NUMBERING KEY	DATE: DECEMBER 2021
		NO: 100-GEN-KEY		SHEET: 1 OF 1

FILE: 100-GEN-KEY.dgn

DISTANCE BETWEEN TRAFFIC SIGNS, "D"

"D" DISTANCES	POSTED SPEED LIMIT, MPH (PRIOR TO WORK AREA)										
	25	30	35	40	45	50	55	60	65	70	75
D (FEET)	250	300	350	400	450	500	550	600	650	700	750

GUIDELINES FOR LENGTH OF LONGITUDINAL BUFFER SPACE, "B"

"B" LENGTHS	SPEED*, MPH (PRIOR TO WORK AREA)											
	20	25	30	35	40	45	50	55	60	65	70	75
B (FEET)	33	50	83	132	181	230	279	329	411	476	542	625

* POSTED SPEED, OFF-PEAK 85TH PERCENTILE SPEED PRIOR TO WORK STARTING, OR THE ANTICIPATED OPERATING SPEED.

MINIMUM MERGING TAPER LENGTH, "L" (FEET)

OFFSET (FEET)	POSTED SPEED LIMIT, MPH (PRIOR TO WORK AREA)										
	25	30	35	40	45	50	55	60	65	70	75
1	11	15	21	27	45	50	55	60	65	70	75
2	21	30	41	54	90	100	110	120	130	140	150
3	32	45	62	80	135	150	165	180	195	210	225
4	42	60	82	107	180	200	220	240	260	280	300
5	53	75	103	134	225	250	275	300	325	350	375
6	63	90	123	160	270	300	330	360	390	420	450
7	73	105	143	187	315	350	385	420	455	490	525
8	84	120	164	214	360	400	440	480	520	560	600
9	94	135	184	240	405	450	495	540	585	630	675
10	105	150	205	267	450	500	550	600	650	700	750
11	115	165	225	294	495	550	605	660	715	770	825
12	125	180	245	320	540	600	660	720	780	840	900
13	136	195	266	347	585	650	715	780	845	910	975
14	146	210	286	374	630	700	770	840	910	980	1050
15	157	225	307	400	675	750	825	900	975	1050	1125

NOT TO SCALE

	NOT TO SCALE	MAINTAINING TRAFFIC TYPICAL	"B", "D" AND "L" TABLES CHANNELIZING DEVICE SPACING, SIGN BORDER KEY, AND ROLL-AHEAD SPACING	DATE: MAY 2021
		NO: 101-GEN-SPACING-CHARTS		SHEET: 1 OF 3

THE FORMULAS FOR THE MINIMUM LENGTH OF A MERGING TAPER IN DERIVING THE "L" VALUES SHOWN IN THE ABOVE TABLES ARE AS FOLLOWS:

"L" = $\frac{W \times S^2}{60}$ WHERE POSTED SPEED PRIOR TO THE WORK AREA IS 40 MPH OR LESS

"L" = W X S WHERE POSTED SPEED PRIOR TO THE WORK AREA IS 45 MPH OR GREATER

L = MINIMUM LENGTH OF MERGING TAPER
 S = POSTED SPEED LIMIT IN MPH PRIOR TO WORK AREA
 W = WIDTH OF OFFSET

TYPES OF TAPERS

UPSTREAM TAPERS

- MERGING TAPER
- SHIFTING TAPER
- SHOULDER TAPER
- 2 TO 1 LANE ROAD TAPER

TAPER LENGTH

- L - MINIMUM
- 1/2 L - MINIMUM
- 1/3 L - MINIMUM
- 100' - MAXIMUM

DOWNSTREAM TAPERS
 (USE IS RECOMMENDED)

100' (PER LANE)

MAXIMUM SPACING FOR CHANNELIZING DEVICES

WORK ZONE SPEED LIMIT	DRUM AND 42" DEVICE SPACING (FT)		NIGHTTIME 42" DEVICE SPACING (FT)	
	TAPER	TANGENT	TAPER	TANGENT
< 45 MPH	1 x SPEED LIMIT	2 x SPEED LIMIT	25 FEET	50 FEET
≥ 45 MPH	50 FEET	100 FEET	25 FEET	50 FEET

SIGN OUTLINE KEY

DASHED OUTLINES INDICATE A SIGN THAT EXISTS ON SITE, AND NEEDS TO BE COVERED.

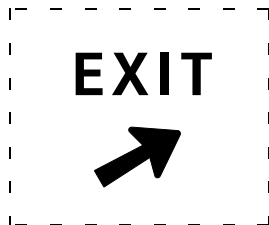

SOLID OUTLINES INDICATE A SIGN THAT IS TO BE PLACED ON THE PROJECT



NOT TO SCALE

	NOT TO SCALE	MAINTAINING TRAFFIC TYPICAL	"B", "D" AND "L" TABLES CHANNELIZING DEVICE SPACING SIGN BORDER KEY AND ROLL-AHEAD SPACING	DATE: MAY 2021
		NO: 101-GEN-SPACING-CHARTS		SHEET: 2 OF 3

GUIDELINES FOR ROLL-AHEAD DISTANCES FOR TMA VEHICLES – TEST LEVEL 2

WEIGHT OF TMA VEHICLE	PREVAILING SPEED (POSTED SPEED PRIOR TO WORK ZONE)	ROLL-AHEAD DISTANCE* (DISTANCE FROM FRONT OF TMA VEHICLE TO WORK AREA)
5.5 TONS (STATIONARY)	40 MPH OR LESS	25 FT

* ROLL-AHEAD DISTANCES ARE CALCULATED USING A 4,410 POUND IMPACT VEHICLE WEIGHT.

GUIDELINES FOR ROLL-AHEAD DISTANCES FOR TMA VEHICLES – TEST LEVEL 3

WEIGHT OF TMA VEHICLE	PREVAILING SPEED (POSTED SPEED PRIOR TO WORK ZONE)	ROLL-AHEAD DISTANCE* (DISTANCE FROM FRONT OF TMA VEHICLE TO WORK AREA)
5 TONS (MOBILE)	45 MPH	100 FT
	50-55 MPH	150 FT
	60-75 MPH	175 FT
12 TONS (STATIONARY)	45 MPH	25 FT
	50-55 MPH	25 FT
	60-75 MPH	50 FT

* ROLL-AHEAD DISTANCES ARE CALCULATED USING A 10,000 POUND IMPACT VEHICLE WEIGHT.



NOT TO SCALE

MAINTAINING TRAFFIC TYPICAL

NO: 101-GEN-SPACING-CHARTS

"B", "D" AND "L" TABLES
CHANNELIZING DEVICE SPACING
SIGN BORDER KEY AND ROLL AHEAD SPACING

DATE: MAY 2021

SHEET: 3 OF 3

THE FOLLOWING NOTES APPLY IF CALLED FOR ON THE TRAFFIC TYPICAL

GENERAL NOTES

- G1: SEE GEN-SPACING-CHARTS FOR COMMON VALUES INCLUDING:
 D = DISTANCE BETWEEN TRAFFIC CONTROL DEVICES
 L = MINIMUM LENGTH OF TAPER
 B = LENGTH OF LONGITUDINAL BUFFER
 ROLL AHEAD DISTANCE
- G2: DISTANCE BETWEEN SIGNS, "D", THE VALUES FOR WHICH ARE SHOWN IN TYPICAL GEN-KEY ARE APPROXIMATE AND MAY NEED ADJUSTING AS DIRECTED BY THE ENGINEER.
- G3: ALL TEMPORARY SIGNS, TYPE III BARRICADES, THEIR SUPPORT SYSTEMS AND LIGHTING MUST MEET NATIONAL COOPERATIVE HIGHWAY RESEARCH PROGRAM REPORT 350 (NCHRP 350) TEST LEVEL 3, OR MANUAL FOR ASSESSING SAFETY HARDWARE (MASH) TL-3 AS WELL AS THE CURRENT EDITION OF THE MICHIGAN MANUAL ON UNIFORM TRAFFIC CONTROL DEVICES, THE CURRENT EDITION OF THE STANDARD SPECIFICATIONS FOR CONSTRUCTION, THE STANDARD PLANS AND APPLICABLE SPECIAL PROVISIONS. ONLY DESIGNS AND MATERIALS APPROVED BY MDOT WILL BE ALLOWED.
- G4: DO NOT STORE EQUIPMENT, MATERIALS OR PERFORM WORK IN ESTABLISHED BUFFER AREAS.
- G5: ALL EXISTING PAVEMENT MARKINGS WHICH ARE IN CONFLICT WITH EITHER PROPOSED CHANGES IN TRAFFIC PATTERNS OR PROPOSED TEMPORARY TRAFFIC MARKINGS SHALL BE REMOVED BEFORE ANY CHANGE IS MADE IN THE TRAFFIC PATTERN. EXCEPTION WILL BE MADE FOR TRAFFIC PATTERNS FOR WORK LESS THAN THREE DAYS THAT ARE ADEQUATELY DELINEATED BY OTHER TRAFFIC CONTROL DEVICES.

SIGN NOTES

- S1: ALL NON-APPLICABLE SIGNING WITHIN THE CIA MUST BE MODIFIED TO FIT CONDITIONS, COVERED, OR REMOVED. FOR GUIDANCE SEE THE WORK ZONE SAFETY AND MOBILITY MANUAL, SECTIONS 6.01.09 AND 6.01.10.
- S2: R5-18b SIGNS ARE ONLY REQUIRED ON FREEWAY PROJECTS WITH A DURATION OF 15 DAYS OR LONGER OR NON-FREEWAY PROJECTS WITH A DURATION OF 90 DAYS OR LONGER. TO APPLY THIS TYPICAL WITHOUT R5-18b SIGNS, REMOVE THE SIGNS AND CONSOLIDATE THE SEQUENCE AS APPROPRIATE.
- S3: R5-18c IS ONLY REQUIRED IN THE INITIAL SIGNING SEQUENCE IN THE WORK ZONE. OMIT THIS SIGN IN SUBSEQUENT SEQUENCES IN THE SAME WORK ZONE.
- S4: ADDITIONAL SIGNING AND/OR ELONGATED SIGNING SEQUENCES SHOULD BE USED WHEN TRAFFIC VOLUMES ARE SIGNIFICANT ENOUGH TO CREATE BACKUPS BEYOND THE W20-5 SIGNS.
- S5: PLACE ADDITIONAL SPEED LIMIT SIGNS REFLECTING THE WORK ZONE SPEED AFTER EACH MAJOR CROSSROAD THAT INTERSECTS THE WORK ZONE, OR AFTER EACH ENTRANCE RAMP THAT COMES ONTO THE FREEWAY WHERE THE REDUCED SPEED IS IN EFFECT. PLACE ADDITIONAL SPEED LIMIT SIGNS AT INTERVALS ALONG THE ROADWAY SUCH THAT NO SPEED LIMIT SIGNS ARE MORE THAN 2 MILES APART. WHEN REDUCED SPEED LIMITS ARE UTILIZED IN THE WORK AREA, PLACE ADDITIONAL SPEED LIMIT SIGNS RETURNING TRAFFIC TO ITS NORMAL SPEED BEYOND THE LIMITS OF THE WORK AREA AS INDICATED. IF PERMANENT SIGNS DISPLAYING THE CORRECT SPEED LIMIT ARE POSTED, OMIT ALL W3-5b AND R2-1 SIGNS AND REDUCE SPACING ACCORDINGLY.
- S6: FABRICATE SPECIAL SIGNS IN ACCORDANCE WITH CURRENT SIGNING DESIGN STANDARDS.
- S7: PLACE ADDITIONAL R8-3 SIGNS AT A MAXIMUM 500' SPACING THROUGHOUT THE WORK ZONE.
- S8: WHEN SPEED LIMIT SIGNS CANNOT BE PLACED SIDE BY SIDE AS SHOWN, PLACE THEM "D" DISTANCE APART.
- S9: STOP SIGNS NOT REQUIRED IF SIGNALS ARE ON 4-WAY FLASHING RED. STOP AHEAD SIGNS ARE NOT REQUIRED IF THERE IS ADEQUATE VISIBILITY OF THE STOP SIGN OR IF SIGNALS ARE BEING USED TO CONTROL TRAFFIC.
- S10: PLACE REDUCED SPEED ZONE AHEAD SIGN (W3-5b) HERE WHEN USING A SPEED REDUCTION IN THIS DIRECTION.
- S11: THE NUMBER OF W1-6 SHIFT SIGNS TO PLACE FOR A SHIFT IS AS FOLLOWS:
 SHIFTS 4FT OR LESS, PLACE ONE W1-6(R)(L)
 SHIFTS 5FT TO 12FT, PLACE TWO W1-6(R)(L)
 SHIFTS MORE THAN 12FT, PLACE THREE OR MORE W1-6(R)(L) SIGNS DEPENDING UPON LENGTH OF SHIFT AND AS PER THE ENGINEER.
- S12: PLACE R2-1 SIGNS AS DETAILED IN NOTE S5 WHEN THERE IS A SPEED REDUCTION IN THIS DIRECTION

TRAFFIC REGULATOR NOTES

- TR1: TRAFFIC REGULATORS MUST FOLLOW ALL THE REQUIREMENTS IN THE STANDARD SPECIFICATIONS, THE STANDARD PLANS AND APPLICABLE SPECIAL PROVISIONS, THE CURRENT VERSIONS OF THE TRAFFIC REGULATOR'S INSTRUCTION MANUAL AND THE VIDEO "HOW TO SAFELY REGULATE TRAFFIC IN MICHIGAN". THE MAXIMUM DISTANCE BETWEEN THE TRAFFIC REGULATORS IS DETERMINED BY THE ROADWAY ADT, GEOMETRICS, AND AS DIRECTED BY THE ENGINEER.
- TR2: PROVIDE APPROPRIATE BALLOON LIGHTING TO SUFFICIENTLY ILLUMINATE TRAFFIC REGULATOR'S STATIONS WHEN TRAFFIC REGULATING IS ALLOWED DURING THE HOURS OF DARKNESS.
- TR3: PROVIDE EITHER A STOP/SLOW AFAD OR A RED/YELLOW LENS AFAD, MEETING THE REQUIREMENTS OF THE MMUTCD

TEMPORARY TRAFFIC CONTROL DEVICE NOTES

- TCD1: THE MAXIMUM DISTANCE IN FEET BETWEEN CHANNELIZING DEVICES IN A TAPER SHOULD NOT EXCEED 1.0 TIMES THE WORK ZONE SPEED LIMIT IN MPH FOR ROADWAYS WITH A POSTED WORK ZONE SPEED LIMIT LESS THAN 45 MPH AND SHOULD NOT EXCEED 50 FEET ON ROADWAYS WITH A POSTED WORK ZONE SPEED LIMIT OF 45 MPH OR GREATER. THE SPACING FOR 42 INCH CHANNELIZING DEVICE TAPERS ARE NOT TO EXCEED 25 FEET AT NIGHT.
- TCD2: THE MAXIMUM DISTANCE IN FEET BETWEEN CHANNELIZING DEVICES IN A TANGENT SHOULD NOT EXCEED TWICE THE WORK ZONE SPEED LIMIT IN MPH FOR ROADWAYS WITH A POSTED WORK ZONE SPEED LIMIT LESS THAN 45 MPH AND SHOULD NOT EXCEED 100 FEET ON ROADWAYS WITH A POSTED WORK ZONE SPEED LIMIT OF 45 MPH OR GREATER. THE SPACING FOR 42 INCH CHANNELIZING DEVICE TANGENTS ARE NOT TO EXCEED 50 FEET AT NIGHT.
- TCD3: TYPE III BARRICADES MUST BE LIGHTED FOR OVERNIGHT CLOSURES.
- TCD4: WHEN THE HAUL ROAD IS NOT IN USE, PLACE LIGHTED TYPE III BARRICADES WITH "ROAD CLOSED" EXTENDING COMPLETELY ACROSS THE HAUL ROAD.
- TCD5: USE OBJECT MARKER SIGNS IN LIEU OF THE TYPE B HIGH INTENSITY LIGHT SHOWN IN THE STANDARD PLAN FOR TEMPORARY CONCRETE BARRIER (R-53, AND R-126) WHEN USED WITH A TEMPORARY SIGNAL SYSTEM. THE OBJECT MARKERS MUST BE A MINIMUM OF 12 INCHES IN WIDTH AND 36 INCHES IN HEIGHT AND HAVE ORANGE AND WHITE RETROREFLECTIVE SHEETING. THE RETROREFLECTIVE SHEETING MUST HAVE ALTERNATING DIAGONAL ORANGE AND WHITE STRIPES SLOPING DOWNWARD AT AN ANGLE OF 45 DEGREES IN THE DIRECTION VEHICULAR TRAFFIC IS TO PASS.
- TCD6: PLACE LIGHTED ARROW PANELS AS CLOSE TO THE BEGINNING OF TAPERS AS PRACTICAL, BUT NOT IN A MANNER THAT WILL OBSCURE OR CONFUSE APPROACHING MOTORISTS WHEN PHYSICAL LIMITATIONS RESTRICT PLACEMENT. IN CURBED SECTIONS, IF ARROW BOARD CANNOT BE PLACED BEHIND CURB, PLACE ARROW BOARD IN THE CLOSED LANE AS CLOSE TO THE BEGINNING OF TAPER AS POSSIBLE.
- TCD7: ADDITIONAL TYPE III BARRICADES MAY BE REQUIRED TO COMPLETELY CLOSE OFF ROAD FROM EDGE OF PAVEMENT TO EDGE OF PAVEMENT.
- TCD8: WHERE THE SHIFTED SECTION IS SHORTER THAN 600 FEET, A DOUBLE REVERSE CURVE SIGN (W24-1) CAN BE USED INSTEAD OF THE FIRST REVERSE CURVE SIGN, AND THE SECOND REVERSE CURVE SIGN CAN BE OMITTED.
- TCD9: RUMBLE STRIPS ARE TO BE PLACED AS SPECIFIED IN THE CONTRACT. IF NOT SPECIFIED IN THE CONTRACT, PLACE RUMBLE STRIPS AS SHOWN, AND IN ACCORDANCE WITH THE RUMBLE STRIP MANUFACTURER'S RECOMMENDATIONS. AN ARRAY OF RUMBLE STRIPS CONTAINS THREE RUMBLE STRIPS. PLACE THE RUMBLE STRIPS IN THE ARRAY AT A CONSISTENT DISTANCE, BETWEEN 10' AND 20' APART.
- TCD10: SEE THE WORK ZONE SAFETY AND MOBILITY MANUAL, PORTABLE CHANGEABLE MESSAGE SIGN GUIDELINES FOR RECOMMENDED AND CORRECT PCMS MESSAGING. STAGGER PCMS THAT ARE ON OPPOSING SIDES OF THE ROAD 1000 FEET FROM EACH OTHER.

RAMP NOTES

- RMP1: WHEN CONDITIONS ALLOW, E5-1 SIGNS MUST BE REMOVED OR COVERED AND CHANNELIZING DEVICES MUST BE POSITIONED TO ENABLE RAMP TRAFFIC TO DIVERGE IN A FREE MANNER
- RMP2: STOP AND YIELD CONDITIONS SHOULD BE AVOIDED WHENEVER PRACTICAL. WHEN CONDITIONS WARRANT, R1-1 SIGNS MAY BE USED IN PLACE OF R1-2 SIGNS. WHEN R-1 SIGNS ARE USED, W3-1 SIGNS MUST BE USED IN PLACE OF W3-2 SIGNS. CONSIDERATION SHOULD BE GIVEN TO CLOSING THE RAMP TO COMPLETE WORK TO ALLOW AN ADEQUATE MERGE DISTANCE. WORK SHOULD BE EXPEDITED TO AVOID THE STOP AND/OR YIELD CONDITIONS.



NOT TO SCALE

MAINTAINING TRAFFIC TYPICAL

NO:

102-GEN-NOTES

**TRAFFIC TYPICALS
NOTE SHEET**

DATE:
MAY 2022
SHEET:

1 OF 2

THE FOLLOWING NOTES APPLY IF CALLED FOR ON THE TRAFFIC TYPICAL

SIGNAL NOTES

- SIG1: EXISTING SIGNAL MUST BE EITHER 4-WAY FLASHING RED, BAGGED, OR TURNED OFF.
- SIG2: SIGNAL IS IN OPERATION.
- SIG3: DELINEATE THE WORK ZONE AREA WITH 28 INCH CONES FOR DAYTIME WORK, OR 42 INCH CHANNELIZING DEVICES FOR NIGHTTIME WORK.
- SIG4: THE CONTRACTOR MUST HAVE A DESIGNATED SPOTTER IF THE AERIAL BUCKET TRUCK IS LOCATED OVER ACTIVE TRAVEL LANES.
- SIG5: THE LOWEST POINT OF THE BUCKET MAY NOT TRAVEL BELOW 14 FOOT VERTICAL CLEARANCE. THE CONTRACTOR MUST UTILIZE AN ALTERNATE SET UP, OR PLACE THE INTERSECTION IN A 4 WAY STOP IF THE 14 FOOT VERTICAL CLEARANCE IS COMPROMIZED. USE TRAFFIC REGULATORS TO CONTROL TRAFFIC THROUGH THE INTERSECTION WHEN TRAFFIC IS PLACED IN A 4 WAY STOP.
- SIG6: DELINEATE THE TRUCK WITH CHANNELIZING DEVICES. THE POSITION OF THE TRUCK MAY BE MOVED TO FACILITATE WORK.

MAINTENANCE AND SURVEYING NOTES

- MS1: WHENEVER STOPPING SIGHT DISTANCE EXISTS TO THE REAR, THE SHADOW VEHICLES SHOULD MAINTAIN THE RECOMENDED DISTANCE FROM THE WORK AREA AND PROCEED AT THE SAME SPEED. THE SHADOW VEHICLE SHOULD SLOW DOWN AND TRAVEL AT A FARTHER DISTANCE TO PROVIDE ADEQUATE SIGHT DISTANCE IN ADVANCE OF VERTICAL OR HORIZONTAL CURVES.
- MS2: WORKERS OUTSIDE OF VEHICLES SHOULD WORK WITHIN 150' OF WORK VEHICLES WITH AN ACTIVATED BEACON, BETWEEN THE "BEGIN WORK CONVOY" SIGN AND THE "END WORK CONVOY" SIGN, OR BETWEEN THE "WORK ZONE BEGINS" AND "END ROAD WORK" SIGN.
- MS3: WORK OR SHADOW VEHICLES WITH OR WITHOUT A TMA MAY BE USED TO SEPARATE THE WORK SPACE FROM TRAFFIC. IF USED, THE VEHICLES SHOULD BE PARKED ACCORDING TO THE ROLL AHEAD DISTANCE TABLES.
- MS4: WORK AND SHADOW VEHICLES SHALL BE APPROPRIATELY EQUIPPED WITH AN ACTIVATED AMBER BEACON.
- MS5: WHEN WORKERS ARE OUTSIDE THEIR VEHICLES IN AN EXISTING LANE WHILE A MOBILE OPERATION IS OCCURRING DURING THE NIGHTTIME HOURS, CHANNELIZING DEVICES TO DELINEATE OPEN OR CLOSED LANES AT 50 FT SPACING MUST BE USED. AN EXAMPLE OF AN OPERATION (BUT NOT LIMITED TO) IS THE LAYOUT OF CONCRETE PATCHES.
- MS6: W21-6 AND W20-1 SIGNS MAY BE SUBSTITUTED AS DETERMINED BY THE TYPE OF WORK TAKING PLACE AS PER THE ENGINEER.



NOT TO SCALE

MAINTAINING TRAFFIC TYPICAL

















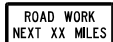
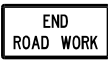





















































NO: 102-GEN-NOTES

TRAFFIC TYPICALS
NOTE SHEET

DATE: MAY 2022
SHEET:

2 OF 2

SIGN NUMBER KEY

 E5-1f 48" x 48" 60" x 48"	 E5-2 48" x 36"	 E5-2a 48" x 36"	 E5-3 48" x 36"	 E13-1P VAR x 24"	 E13-1aP 36" x 24"	 G20-1 60" x 24"	 G20-2 48" x 24"
 G20-4 36" x 18"	 I-6a 18" x 18" 24" x 24" 30" x 30"	 M1-1 18" x 18" 24" x 24" 36" x 36" 48" x 48"	 M1-1 22.5" x 18" 30" x 24" 45" x 36" 60" x 48"	 M1-2 18" x 18" 24" x 24" 36" x 36" 48" x 48"	 M1-2 22.5" x 18" 30" x 24" 45" x 36" 60" x 48"	 M1-3 18" x 18" 24" x 24" 36" x 36" 48" x 48"	 M1-3 22.5" x 18" 30" x 24" 45" x 36" 60" x 48"
 M1-4 18" x 18" 24" x 24" 36" x 36" 48" x 48"	 M1-4 22.5" x 18" 30" x 24" 45" x 36" 60" x 48"	 M1-5 18" x 18" 24" x 24" 30" x 30" 36" x 36"	 M1-5a 18" x 18" 24" x 24"	 M1-6 18" x 18" 24" x 24" 36" X 36"	 M1-6 22.5" x 18" 30" x 24" 45" x 36"	 M3-1 12" x 6" 18" x 9" 24" x 12" 30" x 15" 36" x 18"	 M3-2 12" x 6" 18" x 9" 24" x 12" 30" x 15" 36" x 18"
 M3-3 12" x 6" 18" x 9" 24" x 12" 30" x 15" 36" x 18"	 M3-4 12" x 6" 18" x 9" 24" x 12" 30" x 15" 36" x 18"	 M4-1 12" x 6" 18" x 9" 24" x 12" 30" x 15" 36" x 18"	 M4-1a 12" x 6" 18" x 9" 24" x 12" 30" x 15" 36" x 18"	 M4-2 12" x 6" 18" x 9" 24" x 12" 30" x 15" 36" x 18"	 M4-3 12" x 6" 18" x 9" 24" x 12" 30" x 15" 36" x 18"	 M4-4 18" x 9" 24" x 12" 30" x 15" 36" x 18"	 M4-5 12" x 6" 18" x 9" 24" x 12" 30" x 15" 36" x 18"
 M4-6 12" x 6" 18" x 9" 24" x 12" 30" x 15" 36" x 18"	 M4-7 12" x 6" 18" x 9" 24" x 12" 30" x 15" 36" x 18"	 M4-7a 12" x 6" 18" x 9" 24" x 12" 30" x 15" 36" x 18"	 M4-8 12" x 6" 18" x 9" 24" x 12" 30" x 15"	 M4-8a 24" x 18"	 M4-8b 24" x 12"	 M4-9L 30" x 24" 48" x 36" 60" x 48"	 M4-9R 30" x 24" 48" x 36" 60" x 48"
 M4-9j 30" x 24" 48" x 36" 60" x 48"	 M4-9kL 30" x 24" 48" x 36" 60" x 48"	 M4-9kR 30" x 30" 48" x 42" 60" x 54"	 M4-9mL 30" x 30" 48" x 42" 60" x 54"	 M4-9mR 30" x 30" 48" x 42" 60" x 54"	 M4-9dL 12" x 18"	 M4-9dR 12" x 18"	 M4-9e 12" x 18"
 M4-9f 12" x 18"	 M4-9gL 12" x 18"	 M4-9gR 12" x 18"	 M4-9h 12" x 24"	 M4-9i 12" x 18"	 M4-10L 48" x 18"	 M4-10R 48" x 18"	 M4-11a 12" x 6" 18" x 9" 24" x 12" 30" x 15" 36" x 18"
 M5-1L 12" x 9" 21" x 15" 30" x 21"	 M5-1R 12" x 9" 21" x 15" 30" x 21"	 M5-2L 12" x 9" 21" x 15" 30" x 21"	 M5-2R 12" x 9" 21" x 15" 30" x 21"	 M5-3 12" x 9" 21" x 15" 30" x 21"	 M6-1L 12" x 9" 18" x 12" 21" x 15" 30" x 21"	 M6-1R 12" x 9" 18" x 12" 21" x 15" 30" x 21"	 M6-2L 12" x 9" 18" x 12" 21" x 15" 30" x 21"
 M6-2R 12" x 9" 18" x 12" 21" x 15" 30" x 21"	 M6-3 12" x 9" 18" x 12" 21" x 15" 30" x 21"	 M6-4 12" x 9" 18" x 12" 21" x 15" 30" x 21"	 M6-5 12" x 9" 18" x 12" 21" x 15" 30" x 21"	 M6-6L 12" x 9" 18" x 12" 21" x 15" 30" x 21"	 M6-6R 12" x 9" 18" x 12" 21" x 15" 30" x 21"	 M6-7L 12" x 9" 18" x 12" 21" x 15" 30" x 21"	 M6-7R 12" x 9" 18" x 12" 21" x 15" 30" x 21"

SEE MDOT SHS 13-WORK ZONE FOR SIGN DETAILS

 NO SCALE	MAINTAINING TRAFFIC TYPICAL	STANDARD HIGHWAY SIGNS	DATE: 10/17/24
	CODE: 103-GEN-SIGN		SHEET: 1 OF 5

SIGN NUMBER KEY



M8-1gL
36" x 66"



M8-1gR
36" x 66"

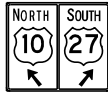

M8-2d
60" x 48"



OM-3L
12" x 36"
24" x 48"
36" x 72"



OM-3R
12" x 36"
24" x 48"
36" x 72"



R1-1
18" x 18"
24" x 24"
30" x 30"
36" x 36"
48" x 48"

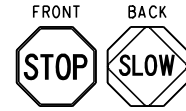

R1-1a
18" x 18"
24" x 24"



R1-2
18"
24"
30"
36"
48"
60"



R1-2aP
24" x 18"
36" x 30"
48" x 36"



R2-1
18" x 24"
24" x 30"
30" x 36"
36" x 48"
48" x 60"



R2-1a
48" x 60"



R3-1
24" x 24"
30" x 30"
36" x 36"
48" x 48"



R3-2
24" x 24"
30" x 30"
36" x 36"
48" x 48"



R3-3
24" x 24"
36" x 36"
48" x 48"



R3-4
24" x 24"
30" x 30"
36" x 36"
48" x 48"



R3-5L
30" x 36"
36" x 48"



R3-5R
30" x 36"
36" x 48"



R3-5a
30" x 36"
36" x 48"



R3-6L
30" x 36"
42" x 48"



R3-6R
30" x 36"
42" x 48"



R3-7L
30" x 30"
36" x 36"



R3-7R
30" x 30"
36" x 36"



R3-8c
36" x 30"

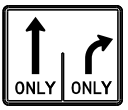

R3-8d
36" x 30"



R4-1
12" x 18"
18" x 24"
24" x 30"
36" x 48"
48" x 60"



R4-2
12" x 18"
18" x 24"
24" x 30"
36" x 48"
48" x 60"



R4-7
12" x 18"
18" x 24"
24" x 30"
36" x 48"
48" x 60"



R4-8
18" x 24"
24" x 30"
36" x 48"
48" x 60"



R4-9
18" x 24"
24" x 30"
36" x 48"
48" x 60"



R5-1
30" x 30"
36" x 36"
48" x 48"



R5-1a
30" x 18"
36" x 24"
42" x 30"



R5-18b
48" x 60"



R5-18c
48" x 48"



R5-18d
78" x 12"



R5-18e
72" x 12"



R5-18f
48" x 60"



R5-18g
30" x 42"



R5-18h
48" x 60"



R6-1L
36" x 12"
54" x 18"



R6-1R
36" x 12"
54" x 18"



R6-2L
12" x 16"
18" x 24"
24" x 30"
36" x 48"
48" x 60"



R6-2R
12" x 16"
18" x 24"
24" x 30"
36" x 48"
48" x 60"



R8-3
12" x 12"
18" x 18"
24" x 24"
36" x 36"
48" x 48"



R9-8
36" x 18"



R9-9
24" x 12"
30" x 18"



R9-10
24" x 12"
48" x 24"



R9-11L
24" x 12"
48" x 36"



R9-11R
24" x 12"
48" x 36"



R9-11aL
24" x 12"
48" x 24"



R9-11aR
24" x 12"
48" x 24"



R10-6b
36" x 54"



R11-2
48" x 30"



R11-2a
48" x 30"



R11-2b
48" x 30"



R11-2c
60" x 30"

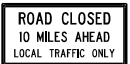

R11-3a
60" x 30"

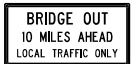

R11-3b
60" x 30"



R11-4
60" x 30"

SEE MDOT SHS 13-WORK ZONE FOR SIGN DETAILS

	MAINTAINING TRAFFIC TYPICAL	STANDARD HIGHWAY SIGNS	DATE: 10/17/24
	CODE: 103-GEN-SIGN		SHEET: 2 OF 5
NO SCALE			

SIGN NUMBER KEY



W1-1L
18" x 18"
24" x 24"
30" x 30"
36" x 36"
48" x 48"



W1-1R
18" x 18"
24" x 24"
30" x 30"
36" x 36"
48" x 48"



W1-2L
18" x 18"
24" x 24"
30" x 30"
36" x 36"
48" x 48"



W1-2R
18" x 18"
24" x 24"
30" x 30"
36" x 36"
48" x 48"



W1-2bL
36" x 36"
48" x 48"



W1-2bR
36" x 36"
48" x 48"



W1-3L
18" x 18"
24" x 24"
30" x 30"
36" x 36"
48" x 48"



W1-3R
18" x 18"
24" x 24"
30" x 30"
36" x 36"
48" x 48"



W1-4L
18" x 18"
24" x 24"
30" x 30"
36" x 36"
48" x 48"



W1-4R
18" x 18"
24" x 24"
30" x 30"
36" x 36"
48" x 48"



W1-4bL
24" x 24"
30" x 30"
36" x 36"
48" x 48"



W1-4bR
24" x 24"
30" x 30"
36" x 36"
48" x 48"



W1-4cL
24" x 24"
30" x 30"
36" x 36"
48" x 48"



W1-4cR
24" x 24"
30" x 30"
36" x 36"
48" x 48"



W24-1L
30" x 30"
36" x 36"
48" x 48"



W24-1cP
24" x 18"
30" x 24"



W24-1R
30" x 30"
36" x 36"
48" x 48"



W24-1aL
30" x 30"
36" x 36"
48" x 48"



W24-1aR
30" x 30"
36" x 36"
48" x 48"



W24-1bL
30" x 30"
36" x 36"
48" x 48"



W24-1bR
30" x 30"
36" x 36"
48" x 48"



W1-6L
24" x 12"
36" x 18"
48" x 24"
60" x 30"
96" x 48"



W1-6R
24" x 12"
36" x 18"
48" x 24"
60" x 30"
96" x 48"



W1-8L
12" x 18"
18" x 24"
24" x 30"
30" x 36"
36" x 48"



W1-8R
12" x 18"
18" x 24"
24" x 30"
30" x 36"
36" x 48"



W3-1
18" x 18"
24" x 24"
30" x 30"
36" x 36"
48" x 48"



W3-2
18" x 18"
24" x 24"
30" x 30"
36" x 36"
48" x 48"

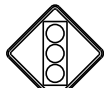

W3-3
18" x 18"
24" x 24"
30" x 30"
36" x 36"
48" x 48"



W3-4
30" x 30"
36" x 36"
48" x 48"
60" x 60"



W3-4b
30" x 30"
36" x 36"
48" x 48"



W3-5
36" x 36"
48" x 48"



W3-5a
30" x 30"
36" x 36"
48" x 48"
60" x 60"



W3-5b
30" x 30"
36" x 36"
48" x 48"



W4-1L
24" x 24"
30" x 30"
36" x 36"
48" x 48"



W4-1R
24" x 24"
30" x 30"
36" x 36"
48" x 48"



W4-2L
30" x 30"
36" x 36"
48" x 48"



W4-2R
30" x 30"
36" x 36"
48" x 48"



W4-3L
30" x 30"
36" x 36"
48" x 48"



W4-3R
30" x 30"
36" x 36"
48" x 48"



W4-5L
24" x 24"
30" x 30"
36" x 36"
48" x 48"



W4-5R
24" x 24"
30" x 30"
36" x 36"
48" x 48"



W4-5P
18" x 24"
24" x 30"



W4-6L
24" x 24"
30" x 30"
36" x 36"
48" x 48"



W4-6R
24" x 24"
30" x 30"
36" x 36"
48" x 48"



W4-7L
30" x 30"
36" x 36"
48" x 48"
60" x 60"



W4-7R
30" x 30"
36" x 36"
48" x 48"
60" x 60"



W5-1
30" x 30"
36" x 36"
48" x 48"



W5-2
18" x 18"
30" x 30"
36" x 36"
48" x 48"



W5-3
24" x 24"
30" x 30"
36" x 36"
48" x 48"



W5-4
30" x 30"
36" x 36"
48" x 48"



W6-1
30" x 30"
36" x 36"
48" x 48"



W6-2
30" x 30"
36" x 36"
48" x 48"



W6-3
30" x 30"
36" x 36"
48" x 48"



W6-4
12" x 18"



W7-1
24" x 24"
30" x 30"
36" x 36"
48" x 48"



W7-1a
24" x 24"
30" x 30"
36" x 36"
48" x 48"



W8-1
18" x 18"
24" x 24"
30" x 30"
36" x 36"
48" x 48"

SEE MDOT SHS 13-WORK ZONE FOR SIGN DETAILS



MAINTAINING TRAFFIC TYPICAL

STANDARD HIGHWAY SIGNS

DATE:
10/17/24















































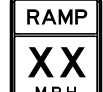



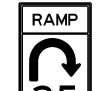



CODE:

103-GEN-SIGN

SHEET:
3 OF 5

NO SCALE

SIGN NUMBER KEY

 DIP W8-2 18" x 18" 24" x 24" 30" x 30" 36" x 36" 48" x 48"	 PAVEMENT ENDS W8-3 18" x 18" 30" x 30" 36" x 36" 48" x 48"	 SOFT SHOULDER W8-4 18" x 18" 24" x 24" 30" x 30" 36" x 36" 48" x 48"	 W8-5 24" x 24" 30" x 30" 36" x 36" 48" x 48"	 WHEN WET W8-5P 24" x 18" 30" x 24" 36" x 30"	 LOOSE GRAVEL W8-7 24" x 24" 30" x 30" 36" x 36" 48" x 48"	 ROUGH ROAD W8-8 24" x 24" 30" x 30" 36" x 36" 48" x 48"	 LOW SHOULDER W8-9 24" x 24" 30" x 30" 36" x 36" 48" x 48"
 UNEVEN LANES W8-11 24" x 24" 30" x 30" 36" x 36" 48" x 48"	 NO CENTER LINE W8-12 30" x 30" 36" x 36" 48" x 48"	 FALLEN ROCKS W8-14 24" x 24" 30" x 30" 36" x 36" 48" x 48"	 GROOVED PAVEMENT W8-15 24" x 24" 30" x 30" 36" x 36" 48" x 48"	 W8-15P 24" x 18" 30" x 24" 36" x 30"	 W8-17L 24" x 24" 30" x 30" 36" x 36" 48" x 48"	 W8-17R 24" x 24" 30" x 30" 36" x 36" 48" x 48"	 SHOULDER DROP-OFF W8-17P 24" x 18" 30" x 24" 36" x 30"
 ROAD MAY FLOOD W8-18 24" x 24" 36" x 36" 48" x 48"	 NO SHOULDER W8-23 24" x 24" 36" x 36" 48" x 48"	 STEEL PLATE AHEAD W8-24 30" x 30" 36" x 36" 48" x 48"	 SHOULDER ENDS W8-25 24" x 24" 30" x 30" 36" x 36" 48" x 48"	 RUMBLE STRIPS AHEAD W8-26 36" x 36" 48" x 48"	 LEFT LANE ENDS W9-1L 24" x 24" 30" x 30" 36" x 36" 48" x 48"	 RIGHT LANE ENDS W9-1R 24" x 24" 30" x 30" 36" x 36" 48" x 48"	 LANE ENDS MERGE LEFT W9-2L 30" x 30" 36" x 36" 48" x 48"
 LANE ENDS MERGE RIGHT W9-2R 30" x 30" 36" x 36" 48" x 48"	 CENTER LANE CLOSED AHEAD W9-3C 30" x 30" 36" x 36" 48" x 48" 60" x 60"	 LEFT LANE CLOSED AHEAD W9-3L 30" x 30" 36" x 36" 48" x 48" 60" x 60"	 RIGHT LANE CLOSED AHEAD W9-3R 30" x 30" 36" x 36" 48" x 48" 60" x 60"	 CENTER & LEFT LANE CLOSED AHEAD W9-3a 30" x 30" 36" x 36" 48" x 48" 60" x 60"	 CENTER & LEFT 2 LANES CLOSED AHEAD W9-3b 30" x 30" 36" x 36" 48" x 48" 60" x 60"	 W11-10 24" x 24" 30" x 30" 36" x 36" 48" x 48"	 TRUCK CROSSING W11-10a 24" x 24" 30" x 30" 36" x 36" 48" x 48"
 WATCH FOR RAMP TRAFFIC W11-24 36" x 36" 48" x 48"	 W12-1 24" x 24" 30" x 30" 36" x 36" 48" x 48"	 12'-6" W12-2 18" x 18" 30" x 30" 36" x 36" 48" x 48"	 35 M.P.H. W13-1P 18" x 18" 24" x 24" 30" x 30"	 EXIT XX MPH W13-2 24" x 30" 36" x 48" 48" x 60"	 RAMP XX MPH W13-3 24" x 30" 36" x 48" 48" x 60"	 ON RAMP W13-4P 24" x 24" 36" x 36"	 EXIT 25 MPH W13-6 24" x 42" 36" x 60" 48" x 84"
 EXIT 25 MPH W13-6a 24" x 42" 36" x 60" 48" x 84"	 RAMP 25 MPH W13-7 24" x 42" 36" x 60" 48" x 84"	 RAMP 25 MPH W13-7a 24" x 42" 36" x 60" 48" x 84"	 NO PASSING ZONE W14-3 36" x 24" 40" x 30" 48" x 36" 64" x 48"	 500 FEET W16-2P 18" x 12" 24" x 18" 30" x 24"	 NEXT X MILES W16-4aP 18" x 12" 24" x 18" 30" x 24" 36" x 30"	 TRAFFIC CIRCLE W16-12P 24" x 18"	 WHEN FLASHING W16-13P 24" x 18" 30" x 24"
 ROAD WORK AHEAD W20-1 24" x 24" 30" x 30" 36" x 36" 48" x 48" 60" x 60"	 STREET WORK AHEAD W20-1a 24" x 24" 30" x 30" 36" x 36" 48" x 48" 60" x 60"	 RAMP WORK AHEAD W20-1b 24" x 24" 30" x 30" 36" x 36" 48" x 48" 60" x 60"	 SIGNAL WORK AHEAD W20-1c 24" x 24" 30" x 30" 36" x 36" 48" x 48" 60" x 60"	 SURVEY WORK AHEAD W20-1d 24" x 24" 30" x 30" 36" x 36" 48" x 48" 60" x 60"	 DETOUR AHEAD W20-2 30" x 30" 36" x 36" 48" x 48"	 ROAD CLOSED AHEAD W20-3 30" x 30" 36" x 36" 48" x 48"	 STREET CLOSED AHEAD W20-3a 30" x 30" 36" x 36" 48" x 48"

SEE MDOT SHS 13-WORK ZONE FOR SIGN DETAILS



MAINTAINING TRAFFIC TYPICAL

STANDARD HIGHWAY SIGNS

DATE:
10/17/24

CODE:

103-GEN-SIGN

SHEET:
4 OF 5

NO SCALE

SIGN NUMBER KEY



W20-3b
30" x 30"
36" x 36"
48" x 48"



W20-4
30" x 30"
36" x 36"
48" x 48"



W20-4c
36" x 36"
48" x 48"



W20-5C
30" x 30"
36" x 36"
48" x 48"



W20-5L
30" x 30"
36" x 36"
48" x 48"



W20-5L1
30" x 30"
36" x 36"
48" x 48"



W20-5L2
30" x 30"
36" x 36"
48" x 48"



W20-5R
30" x 30"
36" x 36"
48" x 48"



W20-5R1
30" x 30"
36" x 36"
48" x 48"



W20-5R2
30" x 30"
36" x 36"
48" x 48"



W20-5aL2
30" x 30"
36" x 36"
48" x 48"



W20-5aL3
30" x 30"
36" x 36"
48" x 48"



W20-5aR2
30" x 30"
36" x 36"
48" x 48"



W20-5aR3
30" x 30"
36" x 36"
48" x 48"



W20-7a
30" x 30"
36" x 36"
48" x 48"



W20-8
24" x 18"



W20-9
54" x 48"



W20-10
48" x 24"
66" x 30"



W20-11
12" x 18"



W20-12P
VARIABLE x 12"



W20-13P
VARIABLE x 12"



W20-14L
36" x 36"
48" x 48"



W20-14R
36" x 36"
48" x 48"



W20-14aP
36" x 12"
48" x 12"



W20-14bP
36" x 12"
48" x 12"



W20-15
36" x 36"
48" x 48"



W20-16
36" x 36"
48" x 48"



W20-17
36" x 36"
48" x 48"



W20-18
48" x 54"



W20-18a
48" x 54"



W21-1
24" x 24"
30" x 30"
36" x 36"
48" x 48"



W21-2
24" x 24"
30" x 30"
36" x 36"
48" x 48"



W21-2
24" x 24"
30" x 30"
36" x 36"
48" x 48"



W21-3
24" x 24"
30" x 30"
36" x 36"
48" x 48"



W21-4
36" x 18"



W21-5
24" x 24"
30" x 30"
36" x 36"
48" x 48"



W21-5aL
30" x 30"
36" x 36"
48" x 48"
60" x 60"



W21-5aR
30" x 30"
36" x 36"
48" x 48"
60" x 60"



W21-5bL
30" x 30"
36" x 36"
48" x 48"
60" x 60"



W21-5bR
30" x 30"
36" x 36"
48" x 48"
60" x 60"



W21-6
24" x 24"
30" x 30"
36" x 36"
48" x 48"



W21-7
30" x 30"
36" x 36"
48" x 48"



W21-8
30" x 30"
36" x 36"
48" x 48"



W22-1
30" x 30"
36" x 36"
48" x 48"



W22-2
42" x 36"



W22-3
36" x 30"
42" x 36"



W23-1
48" x 24"



W23-2
36" x 36"
48" x 48"

SEE MDOT SHS 13-WORK ZONE FOR SIGN DETAILS



MAINTAINING TRAFFIC TYPICAL

STANDARD HIGHWAY SIGNS

DATE:

10/17/24

CODE:

103-GEN-SIGN

SHEET:

5 OF 5

NO SCALE

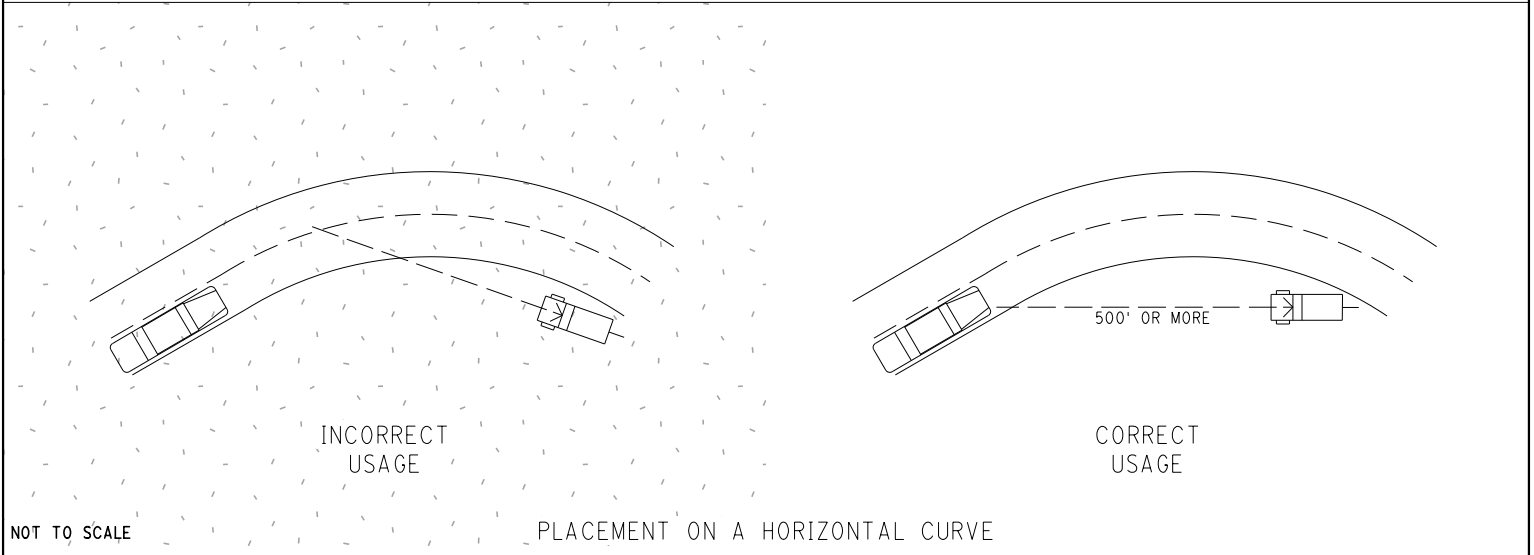
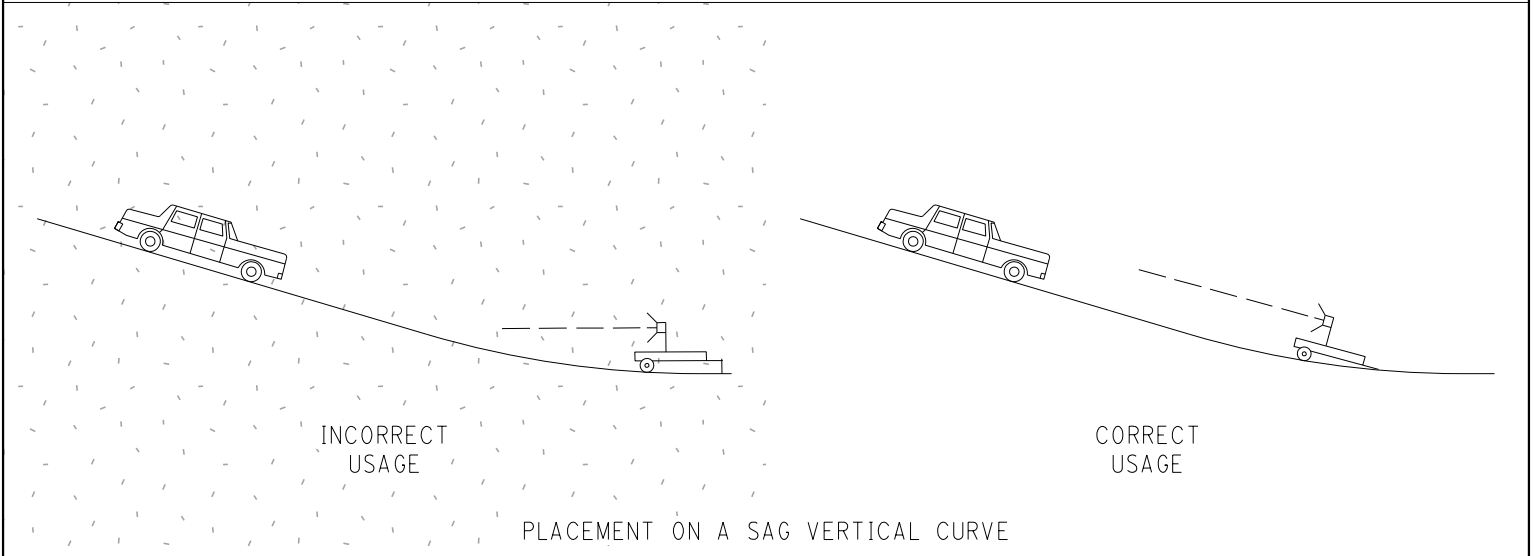
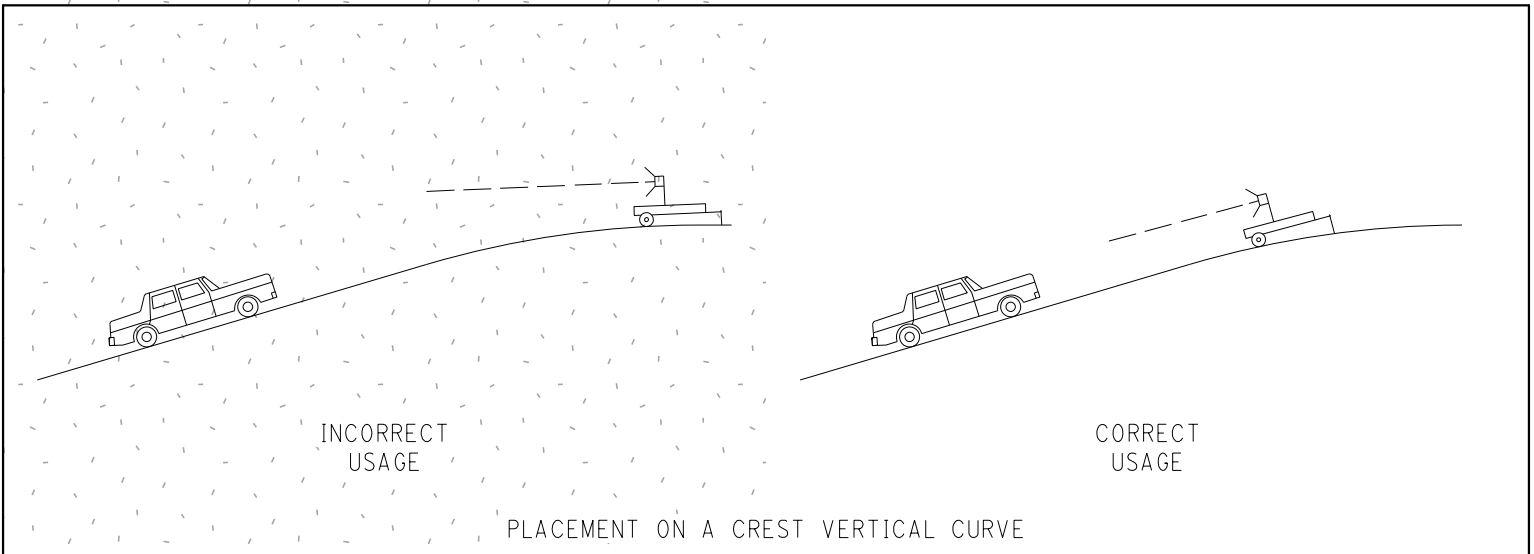

NOTE:

ENSURE THE ARROW REMAINS CLEARLY LEGIBLE AT DISTANCES FROM 2,500 FEET TO 200 FEET, FROM ALL TRAFFIC LANES AND ROADWAY ENTRANCES. DO NOT PLACE THE LIGHTED ARROW ON A HORIZONTAL OR VERTICAL CURVE THAT MIGHT INTERFERE WITH THIS LEGIBILITY REQUIREMENT.

	NOT TO SCALE	MAINTAINING TRAFFIC TYPICAL	USE OF ARROW BOARD ON HILL OR CURVE AND WORK ZONE LAYOUT	DATE: MAY 2021
		NO: 104-GEN-AB		SHEET: 1 OF 1

KEY

- CHANNELIZING DEVICE
- ↑ TRAFFIC FLOW
- ⬆️ LIGHTED ARROW PANEL
- I TYPE III BARRICADE
- ◊ PART OF LEAD-IN SIGNING SEQUENCE
- PLACE SIGN AS INDICATED IN NOTE S5

STANDARD NOTES

(SEE GEN-NOTES)

GENERAL: G1, G2, G3, G4
 SIGNING: S1, S5, S8
 DEVICES: TCD1, TCD2, TCD3, TCD6

MAJOR INTERSECTION

MAJOR INTERSECTION

MAJOR INTERSECTION

GREATER THAN 2 MILES
 LESS THAN 4 MILES

LESS THAN 2 MILES

LESS THAN 2 MILES



NOT TO SCALE

MAINTAINING TRAFFIC TYPICAL

NO:
106-GEN-SPEED-NFW

**SUPPLEMENTAL SPEED LIMIT
 TREATMENT ON A 2-WAY ROADWAY
 WHERE WORKERS PRESENT**

DATE:
 DECEMBER 2021
 SHEET:

1 OF 1

NO SPEED REDUCTION THROUGH WORK ZONE

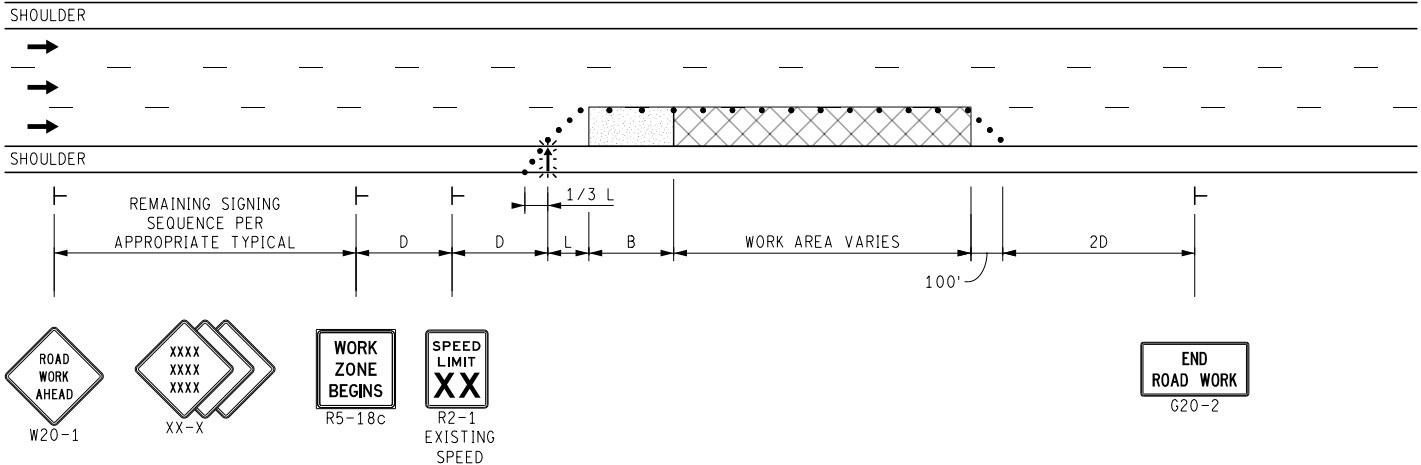

REDUCED SPEED THROUGH WORK ZONE

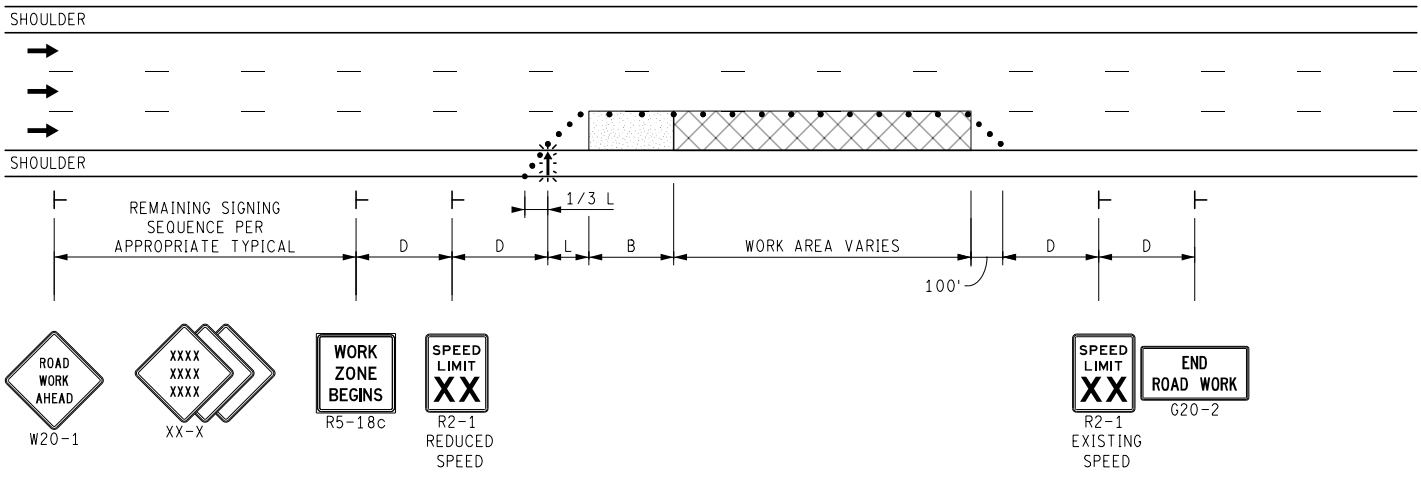



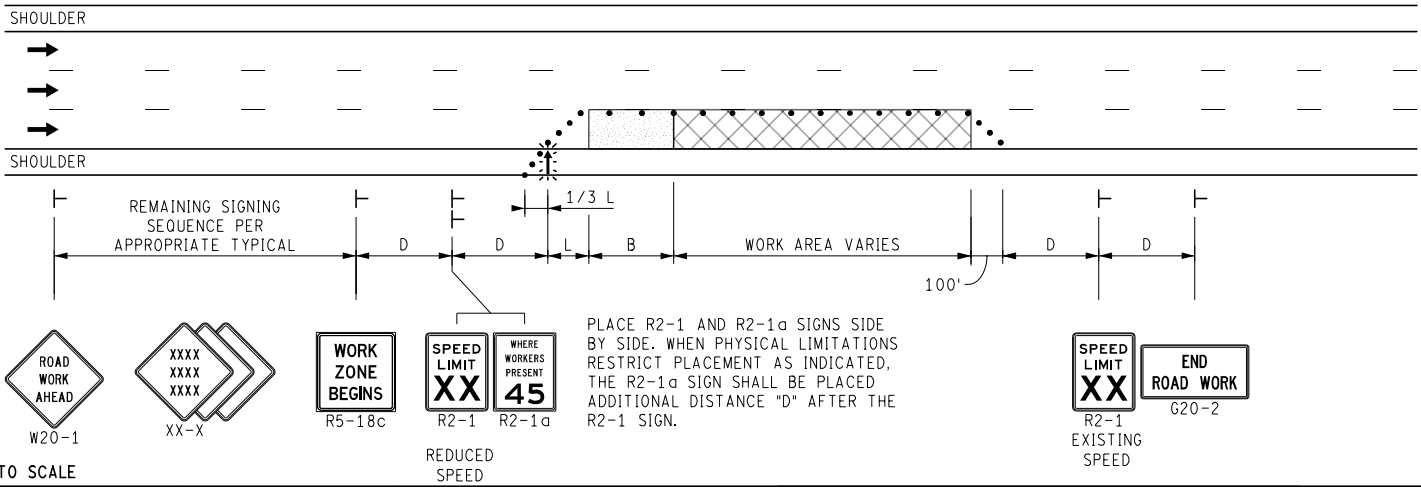



REDUCED SPEED THROUGH WORK ZONE USING "WHERE WORKERS PRESENT"



NOT TO SCALE

	NOT TO SCALE	MAINTAINING TRAFFIC TYPICAL	SPEED LIMIT LAYOUT	DATE: MAY 2021
		NO: 107-GEN-SPEED		

KEY

-  TRAFFIC REGULATOR
-  CHANNELIZING DEVICES
-  LIGHTED ARROW PANEL (CAUTION MODE)
-  TRAFFIC FLOW
-  REFLECTS EXISTING SPEED LIMIT
-  PLACE SIGN AS INDICATED IN NOTE S5
-  PLACE SIGN AS INDICATED IN NOTE S2

STANDARD NOTES

(SEE GEN-NOTES)

GENERAL: G1, G2, G3, G4
 SIGNING: S1, S2, S3, S4, S5
 TRAF REG: TR1, TR2
 DEVICES: TCD1, TCD2, TCD6

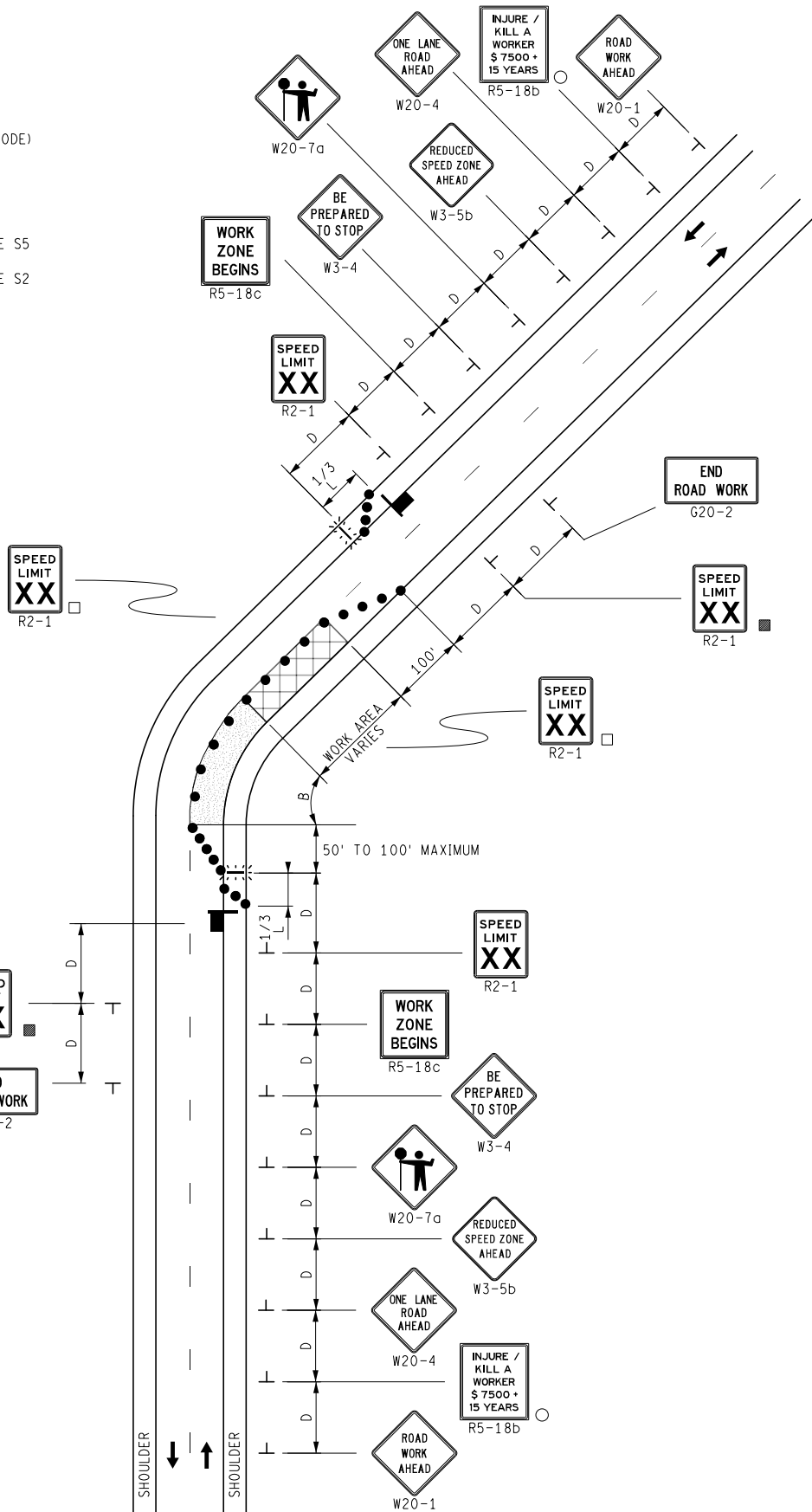

	NOT TO SCALE	MAINTAINING TRAFFIC TYPICAL	LANE CLOSURE UTILIZING TRAFFIC REGULATORS ON A 2-LANE UNDIVIDED ROADWAY	DATE: MAY 2021
		NO: 110-TR-NFW-2L		SHEET: 1 OF 1

FILE: 110-TR-NFW-2L.dgn

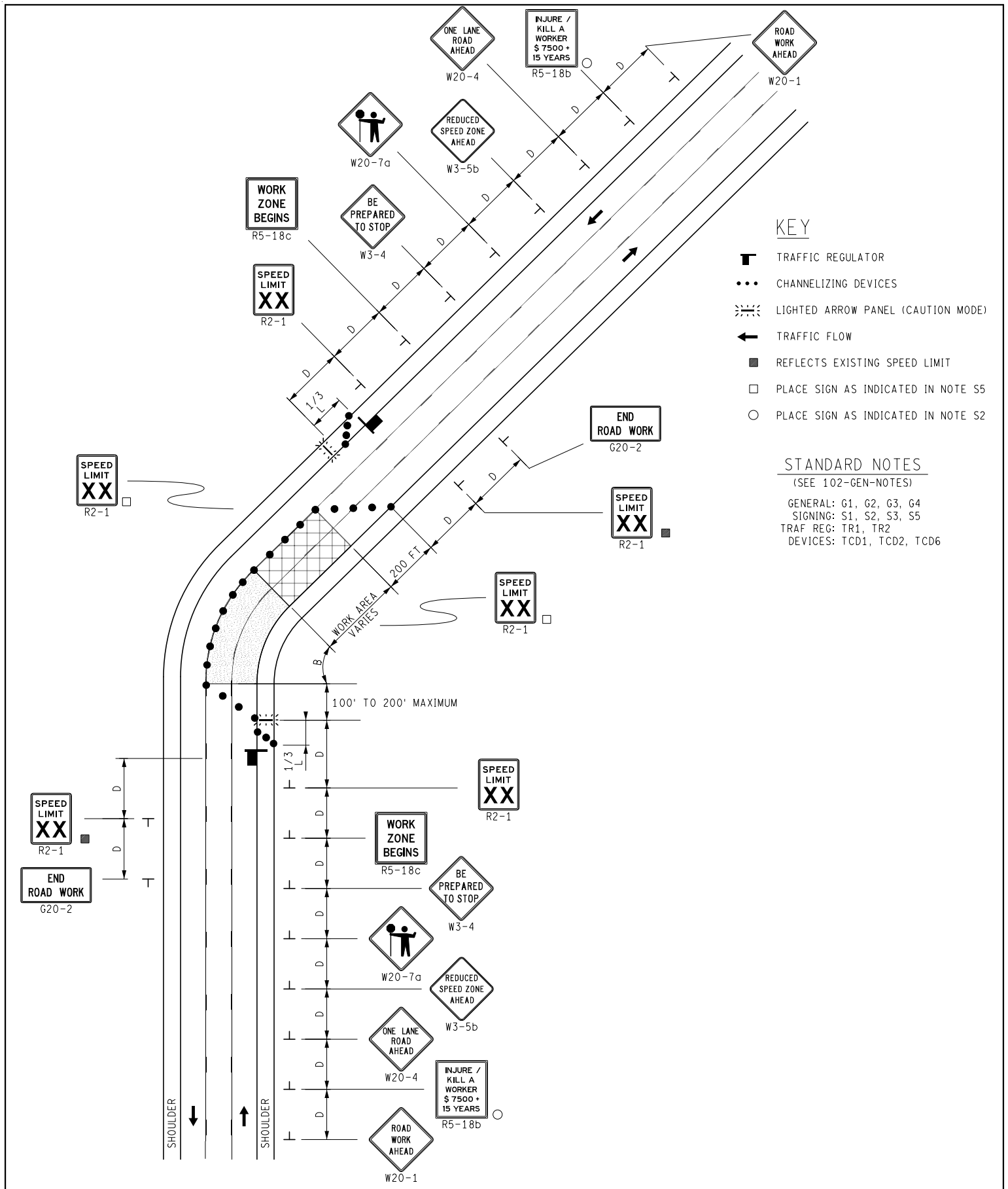

NOT TO SCALE

MAINTAINING TRAFFIC TYPICAL

NO:

112-TR-CLT

1-LANE AND CLTL CLOSURE
UTILIZING TRAFFIC REGULATORS
ON A 3-LANE UNDIVIDED ROADWAY

DATE: MAY 2021
SHEET:

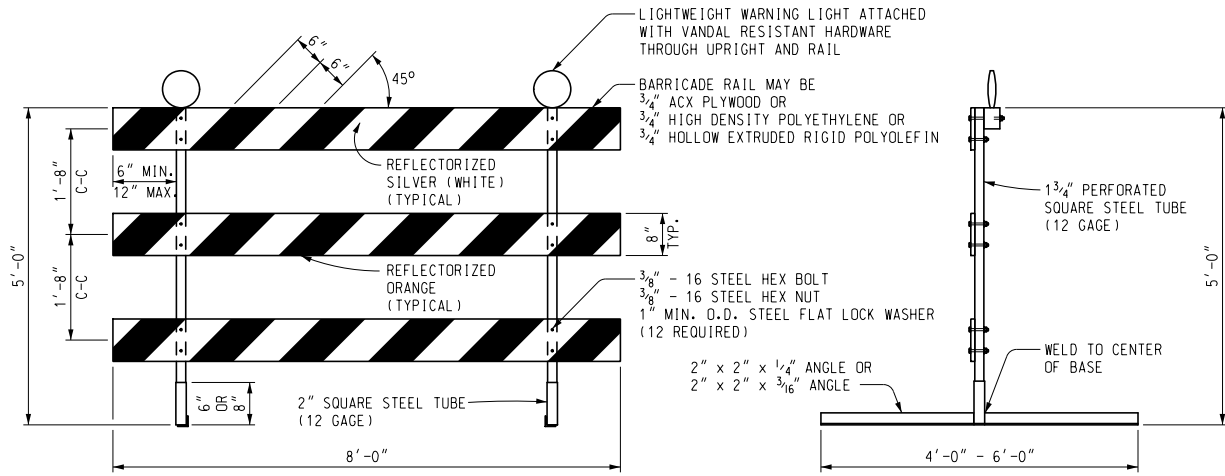

FRONT ELEVATION SIDE VIEW
PERFORATED SQUARE STEEL TUBE OPTION

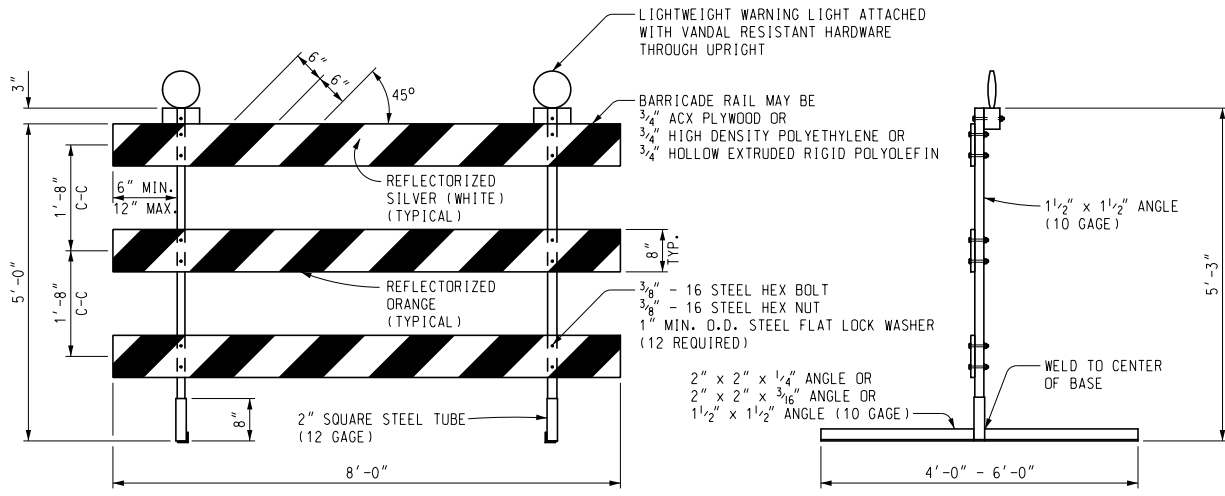

FRONT ELEVATION SIDE VIEW
ANGLE IRON OPTION

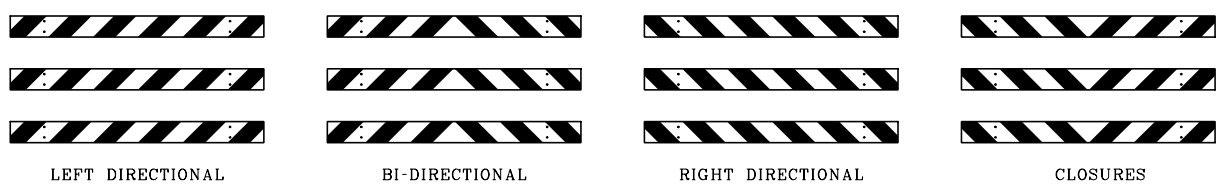

**BARRICADE RAIL SHEETING OPTIONS
 TYPE III BARRICADES**

Other Type III Barricades meeting current NCHRP crash worthy criteria can be found on the FHWA Safety website at http://safety.fhwa.dot.gov/roadway_dept/road_hardware/wzd.htm

<p>PREPARED BY OPERATIONS FIELD SERVICES</p> <p>DRAWN BY: <u>ECH</u></p> <p>CHECKED BY: <u>MWB</u></p>	<p>DEPARTMENT DIRECTOR Paul C. Ajegba</p> <p>APPROVED BY: _____ DIRECTOR, BUREAU OF FIELD SERVICES</p>	<p>MICHIGAN DEPARTMENT OF TRANSPORTATION BUREAU OF FIELD SERVICES SPECIAL DETAIL FOR</p> <p style="text-align: center;">Temporary Traffic Control Devices</p>	
	<p>APPROVED BY: _____ (SPECIAL DETAIL) DIRECTOR, BUREAU OF HIGHWAY DEVELOPMENT</p>	<p>F.H.W.A. APPROVAL</p>	<p>6/16/22 PLAN DATE</p>

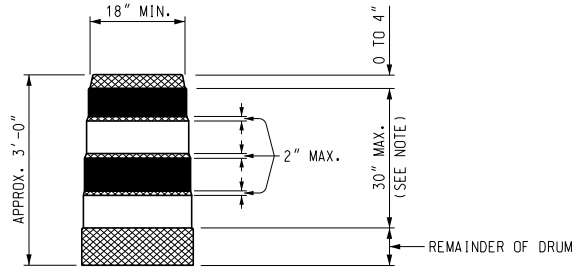

- REFLECTORIZED ORANGE
- REFLECTORIZED WHITE
- NON REFLECTORIZED ORANGE

NOTE:
 DRUMS SHALL HAVE AT LEAST 4 HORIZONTAL REFLECTORIZED STRIPES (2 ORANGE AND 2 WHITE) OF 6" UNIFORM WIDTH, ALTERNATING IN COLOR WITH THE TOPMOST REFLECTORIZED STRIPE BEING ORANGE. NON REFLECTORIZED SPACES BETWEEN THE HORIZONTAL REFLECTORIZED ORANGE AND WHITE STRIPES SHALL BE ORANGE IN COLOR AND EQUAL IN WIDTH.

PLASTIC DRUM

NOTES:

2" PERFORATED SQUARE STEEL TUBES MAY BE USED TO FABRICATE THE HORIZONTAL BASE OF THE TYPE III BARRICADE.

WARNING LIGHTS SHALL BE PLACED ACCORDING TO THE CURRENT STANDARD SPECIFICATIONS FOR CONSTRUCTION AND ALL OTHER PROVISIONS IN THE CONTRACT ON TYPE III BARRICADES.

SEE ROAD STANDARD PLANS R-113-SERIES FOR TEMPORARY CROSSOVERS FOR DIVIDED ROADWAY, AND R-126-SERIES FOR TYPICAL LOCATION AND SPACING OF PLASTIC DRUMS FOR PLACEMENT OF TEMPORARY CONCRETE BARRIER.

SIGNS, BARRICADES, AND PLASTIC DRUMS SHALL BE FACED WITH PRESSURE-SENSITIVE REFLECTIVE SHEETING ACCORDING TO THE CURRENT STANDARD SPECIFICATIONS FOR CONSTRUCTION.

SANDBAGS SHALL BE USED WHEN SUPPLEMENTAL WEIGHTS ARE REQUIRED TO ACHIEVE STABILITY OF THE BARRICADE. THE SANDBAGS SHALL BE PLACED SO THEY WILL NOT COVER OR OBSTRUCT ANY REFLECTIVE PORTION OF THE TRAFFIC CONTROL DEVICE.

NOT TO SCALE

MICHIGAN DEPARTMENT OF TRANSPORTATION
 BUREAU OF FIELD SERVICES SPECIAL DETAIL

(SPECIAL DETAIL)
 F.H.W.A. APPROVAL

6/16/22
 PLAN DATE

WZD-125-E

SHEET
 3 OF 3

NOTE: THE ORIGINAL SIGNED COPY IS KEPT ON FILE AT THE MICHIGAN DEPARTMENT OF TRANSPORTATION.